

STANDARD, HIGH PRESSURE (HPBV) AND SIGHT GLASS (BVSG) BALL VALVES

HIGH PRESSURE BALL VALVE

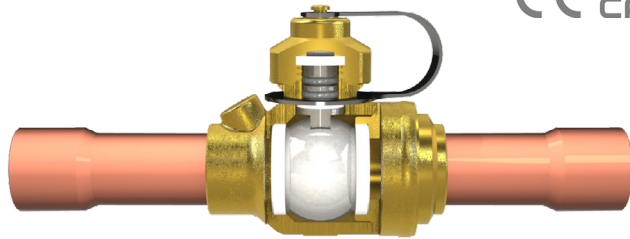

Applications

Ball Valves are used in a wide variety of air conditioning and refrigeration applications. They can be used for both liquid and gas applications. This type of valve is commonly used for isolating purposes. All valves are suitable for CO₂, HCFC and HFC refrigerants along with their associated oils. Additionally, standard models up to and including 3" 1/8 and 76mm sizes are suitable for R290 and A2L gases compatible with the valve materials.

The BVSG combines the traditional ball valve with a sight glass and moisture indicator. A typical location for this combination product is in the liquid refrigerant line. The ball valve is used for isolating purposes, the sight glass for a visual display inside the line and the moisture indicator monitors the moisture content in the system.

The HPBV is suitable for transcritical CO₂ applications.

Main Features

Construction Features

- Bi-directional flow
- Indicator on stem shows valve position - open or closed
- Positive stem stop ensures precise positioning in the open or closed position
- Blow-out proof stem
- Ball cavity vented to prevent over-pressure
- Vented seal cap
- Schrader valve option
- Mounting pad
- Large clear sight glass (BVSG only)
- Positive colour contrast indicator (BVSG only)
- Plastic protection cap for sight glass supplied as standard (BVSG only)
- UL listed (standard range up to including 907409/937409 models only, excluding "M" and "SG" versions)

BALL VALVE WITH SIGHT GLASS

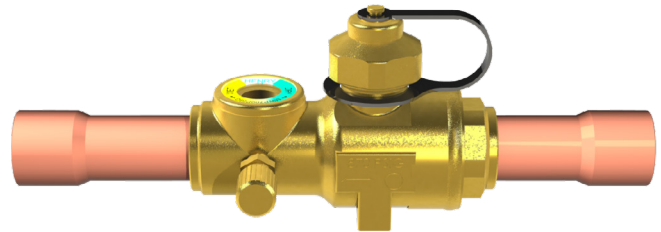

Sealing Integrity Features

- Premium quality PTFE ball seals
- Premium quality TFM™ ball seals (HPBV only)
- Double O-ring system seal design
- Premium quality neoprene stem O-ring seals (not HPBV)
- Premium quality HNBR stem O-ring seals (HPBV)
- Seal cap retainer - prevents loss of cap
- PTFE cap seal - acts as a secondary seal
- Hermetically sealed sight glass (BVSG only)

Technical Specifications

Allowable Operating Temperature: -40°C to +120°C

Allowable Operating Temperature: -40°C to +150°C (HPBV)

Allowable Operating Pressure: 0 to 48 barg/60 barg

Allowable Operating Pressure: 0 to 130 barg (HPBV)

Materials of Construction

The valve body, valve body adaptor, ball and seal cap are made from brass. The stem is made from brass or plated steel. The pipe extensions are made from copper/K65 copper alloy. The ball seals are made from virgin PTFE/TFM, stem O-rings from neoprene/HNBR and cap seal from PTFE.

Installation - Main Issues

The valve body must be protected against excessive heat during installation to prevent damage to the seals. Full details are provided in the installation sheet, included with each valve.

Installation Instructions



Scan or click the QR Code to download the full product installation and application instructions from our website.

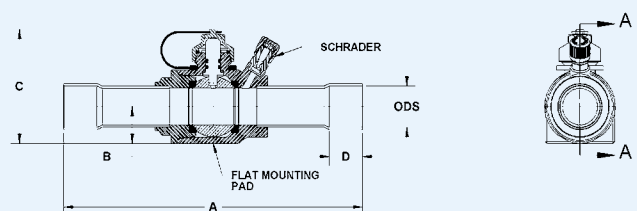

STANDARD BALL VALVE WITH SCHRADER VALVE

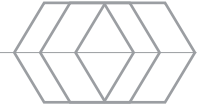

BALL VALVES IMPERIAL

Part No		ODS (inch)	Dimensions (mm)					Port Size (mm)	Weight (kg)	MWP (barg)	Kv Value (m ³ /hr)	CE/UKCA Cat
Standard	Schrader Valve		A	B	C	D	Mounting pad hole thread details -2 off					
907202	937202	1/4	165	16	58	8	8-36 UNF-2B X 20 pitch	12.70	0.33	60	1.81	SEP
907203	937203	3/8	165	16	58	8	8-36 UNF-2B X 20 pitch	12.70	0.33	60	3.70	SEP
907204	937204	1/2	165	16	58	10	8-36 UNF-2B X 20 pitch	12.70	0.33	60	6.02	SEP
907205	937205	5/8	165	16	58	13	8-36 UNF-2B X 20 pitch	12.70	0.33	60	11.95	SEP
907306	937306	3/4	184	21	71	16	8-36 UNF-2B X 32 pitch	19.05	0.62	60	18.06	SEP
907307	937307	7/8	184	21	71	19	8-36 UNF-2B X 32 pitch	19.05	0.64	60	26.06	SEP
907409	937409	1 1/8	216	25	80	23	10-32 UNF-2B X 40 pitch	25.40	0.95	60	52.72	Cat II
908511	938511	1 3/8	235	31	98	25	10-32 UNF-2B X 48 pitch	31.75	1.52	60	73.27	Cat II
908613	938613	1 5/8	254	39	113	28	1/4"-28 UNF-2B X 60 pitch	38.10	2.44	60	182.32	Cat II
908617	938617	2 1/8	289	47	136	34	1/4"-28 UNF-2B X 75 pitch	50.80	4.58	60	245.10	Cat II
908721	938721	2 5/8	327	47	136	37	1/4"-28 UNF-2B X 75 pitch	50.80	5.04	60	204.68	Cat II
908721FP	937821FP	2 5/8	365	60	158	37	1/4"-28 UNF-2B X 75 pitch	63.50	8.73	60	258.86	Cat II
908725	938725	3 1/8	365	60	158	42	1/4"-28 UNF-2B X 75 pitch	63.50	8.73	60	278.64	Cat II
908825FP	-	3 1/8	420	72	182	43	5/16-24 UNF-2B X 104 pitch	80.00	18.20	48	361.20	Cat II
908829*	-	3-5/8	420	72	182	43	5/16-24 UNF-2B X 104 pitch	80.00	18.20	48	439.46	Cat I
908833*	-	4-1/8	420	72	182	56	5/16-24 UNF-2B X 104 pitch	80.00	18.20	48	447.20	Cat I

*Unsuitable for hazardous fluids.

BALL VALVES METRIC

Part No		ODS (mm)	Dimensions (mm)					Port Size (mm)	Weight (kg)	MWP (barg)	Kv Value (m ³ /hr)	CE/UKCA Cat
Standard	Schrader Valve		A	B	C	D	Mounting pad hole thread details -2 off					
907206M	937206M	6	165	16	58	8	8-36 UNF-2B X 20 pitch	12.70	0.33	60	1.81	SEP
907210M	937210M	10	165	16	58	8	8-36 UNF-2B X 20 pitch	12.70	0.33	60	3.70	SEP
907212M	937212M	12	165	16	58	10	8-36 UNF-2B X 20 pitch	12.70	0.33	60	6.02	SEP
907205	937205	16	165	16	58	13	8-36 UNF-2B X 20 pitch	12.70	0.33	60	11.95	SEP
907318M	937318M	18	184	21	71	17	8-36 UNF-2B X 32 pitch	19.05	0.62	60	18.06	SEP
907307	937307	22	184	21	71	20	8-36 UNF-2B X 32 pitch	19.05	0.64	60	26.06	SEP
908428M	938428M	28	216	25	80	24	10-32 UNF-2B X 40 pitch	25.40	0.95	60	52.72	Cat II
908511	938511	35	235	31	98	25	10-32 UNF-2B X 48 pitch	31.75	1.52	60	73.27	Cat II
908642M	938642M	42	254	39	113	28	1/4"-28 UNF-2B X 60 pitch	38.10	2.44	60	182.32	Cat II
908617	938617	54	289	48	136	35	1/4"-28 UNF-2B X 75 pitch	50.80	4.58	60	245.10	Cat II
908764M	938764M	64	327	48	136	35	1/4"-28 UNF-2B X 75 pitch	50.80	5.04	60	204.68	Cat II
908764MFP	938764MFP	64	365	60	158	35	1/4"-28 UNF-2B X 75 pitch	63.50	8.73	60	258.86	Cat II
908776M	938776M	76	365	60	158	43	1/4"-28 UNF-2B X 75 pitch	63.50	8.73	60	278.64	Cat II
907889M*	-	89	420	72	182	43	5/16-24 UNF-2B X 104 pitch	80.00	18.20	48	361.20	Cat I
9078108M*	-	108	420	72	182	58	5/16-24 UNF-2B X 104 pitch	80.00	18.20	48	439.46	Cat I

*Unsuitable for hazardous fluids.

BALL VALVE WITH SIGHT GLASS

Part No		ODS (inch)	ODS (mm)	Dimensions (mm)					Port Size (mm)	Weight (kg)	MWP (barg)	Kv Value (m ³ /hr)	CE/UKCA Cat
Standard	Schrader Valve			A	B	C	D	Mounting pad hole thread details -2 off					
907202SG	937202SG	1/4	-	185	16	59	8	8-36 UNF-2B X 20 pitch	12.70	0.42	60	1.81	SEP
907203SG	937203SG	3/8	-	185	16	59	8	8-36 UNF-2B X 20 pitch	12.70	0.42	60	3.70	SEP
907204SG	937204SG	1/2	-	185	16	59	10	8-36 UNF-2B X 20 pitch	12.70	0.42	60	6.02	SEP
907205SG	937205SG	5/8	16	185	16	59	13	8-36 UNF-2B X 20 pitch	12.70	0.42	60	11.95	SEP
907306SG	937306SG	3/4	-	211	21	71	19	8-36 UNF-2B X 32 pitch	19.05	0.80	60	18.06	SEP
907307SG	937307SG	7/8	22	211	21	71	20	8-36 UNF-2B X 32 pitch	19.05	0.80	60	26.06	SEP
907409SG	937409SG	1 1/8	-	237	26	80	24	10-32 UNF-2B X 40 pitch	25.40	1.20	60	52.72	Cat II



MOISTURE COLOUR TABLE

Refrigerant	Moisture content (parts per million)			
	Temp (°C)	Indicator Colour		
		Green	Chartreuse	Yellow
R404A	24	below 20	20-100	above 100
	38	below 35	35-130	above 130
	52	below 45	45-200	above 200
R410A	24	below 20	20-100	above 100
	38	below 30	30-120	above 120
	52	below 50	50-150	above 150
R134a	24	below 30	30-90	above 90
	38	below 50	50-120	above 120
	52	below 70	70-150	above 150
R744	24	below 15	15-80	above 80
	38	below 20	20-90	above 90
	52	below 35	35-110	above 110

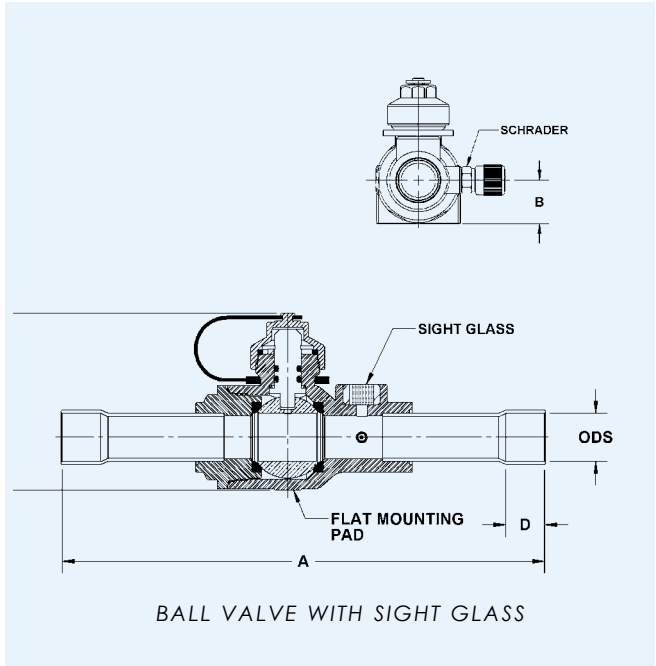

HIGH PRESSURE BALL VALVES

Part No:		ODS (Inch)	ODS (mm)	Dimensions (mm)					Port Size (mm)	Weight (kg)	MWP (barg)	Kv Value (m ³ /hr)	CE/UKCA Cat
Standard	Schrader Valve			A	B	C	D	Mounting pad hole thread details - 2 off					
907202TH	937202TH	1/4	-	165	16	58	8	8-36 UNF-2B X 20 mm pitch	12.70	0.33	130	1.81	SEP
907203TH	937203TH	3/8	-	165	16	58	8	8-36 UNF-2B X 20 mm pitch	12.70	0.33	130	3.70	SEP
907204TH	937204TH	1/2	-	165	16	58	10	8-36 UNF-2B X 20 mm pitch	12.70	0.33	130	6.02	SEP
907205TH	937205TH	5/8	16	165	16	58	13	8-36 UNF-2B X 20 mm pitch	12.70	0.33	130	11.95	SEP
907306TH	937306TH	3/4	-	184	21	71	16	8-36 UNF-2B X 32 mm pitch	19.05	0.62	130	18.06	SEP
907307TH	937307TH	7/8	22	184	21	71	19	8-36 UNF-2B X 32 mm pitch	19.05	0.64	130	26.06	SEP
907409TH	937409TH	1-1/8	-	216	25	80	23	10-32 UNF-2B X 40 mm pitch	25.40	0.95	130	52.72	SEP
907511TH	937511TH	1-3/8	35	235	31	98	25	10-32 UNF-2B X 48 mm pitch	31.75	1.52	130	73.27	Cat I
907613TH	937613TH	1-5/8	-	254	39	113	28	1/4"-28 UNF-2B X 60 mm pitch	38.10	2.44	130	182.32	Cat I

