

Data Sheet

Superheat controller Type **EIM 336**

For stepper motor valves

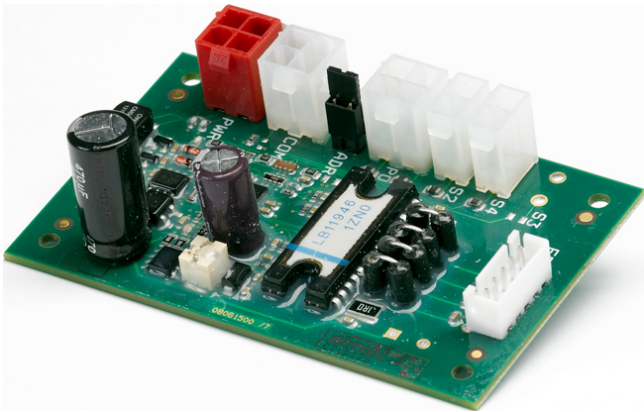

The EIM 336 is a superheat controller that can be used to control the opening degree of a valve based on the superheat of the evaporator. This is applicable in applications such as air conditioning, heat pumps and refrigeration.

An alternative option is to use the controller in manual mode via modbus communication and use it as a valve driver by setting the valve opening degree manually.

Benefits





- The evaporator is charged optimally even when there are large variations in load and suction pressure.
- The superheat control can save energy by ensuring optimum utilization of the evaporator.
- The superheat is controlled to the lowest stable value.
- It controls EEV in microsteps providing a smooth superheat curve and less noise.

Features

- Minimum Stable Superheat search regulation (MSS).
- Maximum Operating Pressure function (MOP).
- Defrost.
- Compressor protection functions.
- Evaporator temperature (T_e) control for dehumidifying.
- Valve driver via Modbus Communication.
- Loss Of Charge indication (LOC).

1 Portfolio overview

Table 1: Related products

Pressure transducer DST P110, AKS 32R, NSK BExx	Temperature sensor AKS 21, AKS 11	Programming key / display MYK - EIM interfacer	Electric Expansion valve ETS6
			

2 Functions

2.1 Acronyms and abbreviations

LOC Loss of charge indication

SH Superheat

MOP Maximum operating pressure

MSS Minimum stable superheat

T_e Saturated suction temperature

P_e (P_o) Evaporator pressure

S₂ Evaporator refrigerant outlet temperature

S₄ Evaporator medium outlet temperature

OD Opening degree

PNU Parameter number - is equivalent to the modbus register no. (modbus adress + 1)

2.2 Functions

Minimum Stable Superheat (MSS)

The controller will search for the minimum stable superheat between an upper and lower boundary set by the user. If the superheat has been stable for a period of 6 minutes, the superheat reference is decreased. If the superheat becomes unstable, the reference is raised again. This process continues as long as the superheat is within the bounds set by the user. The purpose of this is to search for the lowest possible superheat that can be obtained while still maintaining a stable system. The superheat reference can also be fixed, in which case this function is disabled.

Maximum Operating Pressure (MOP)

In order to reduce the strain on the compressor, a maximum operating pressure can be set. If the pressure comes above this limit the controller will control the valve to provide a lower pressure instead of a low superheat. The limit for this function is usually a fixed pressure, but it is possible to offset the limit temporarily.

Evaporator temperature (T_e) control for de-humidifying

A function is provided to control on the evaporator temperature instead of the superheat. This can be used to de-humidify the air flowing through the evaporator. By lowering the evaporators surface temperature, the water vapor in the air is condensed.

Superheat close

When the superheat is below a set minimum value, the valve will close faster in order to protect the compressor from the risk of getting liquid in the suction line.

Manual control

The valve can be controlled manually by setting the desired opening degree via modbus.

Start/stop of regulation

The start or stop of the regulation can be controlled by setting the software main switch, which is accessible via modbus. It is however also possible to use a digital input from an external Regulation control On / Off switch.

Loss Of Charge indication (LOC)

A function is provided to indicate loss of refrigerant charge. This is only indicated by setting an alarm flag which can be accessed via modbus. No special action is performed by the controller.

External sensor values

The EIM 336 has sensor inputs for the suction pressure and evaporator temperature (S2). It is however possible to substitute these sensor inputs by sending external sensor values via modbus. These external values need to be updated frequently.

Forced opening during startup

In some applications it is necessary to open the valve quickly when the compressor turns on, to prevent too low suction pressure. This is ensured by setting a fixed opening degree and a startup time for the controller. Note that this will give a fixed opening degree for the duration of the start time, regardless of the superheat value.

Forced opening during off

In some applications the valve must remain open when the controller is off. This can be done by setting a fixed opening degree. When normal control is switched off with the main switch, the valve will keep this opening degree.

Defrost handling

The controller does not itself handle defrost of the evaporator. It is however possible to enter a special defrost sequence, which will overrule the normal control of the valve.

Standalone function

The EIM 336 is designed to operate in conjunction with a system master controller, which will control the EIM 336 via modbus. It is however possible to use it in a standalone mode with no external control, except a digital input from the Regulation control On / Off switch. In this configuration some of the other functions will not be available.

3 Applications

3.1 Regulation control

The evaporator superheat is controlled by one pressure sensor Pe (evaporator pressure) and one temperature sensor S2 (refrigerant temperature). Alternatively the pressure and temperature signals can be received as data via modbus. This can be useful if the pressure and temperature sensors are mounted on a separate controller.

Fitting the S4 (evaporator medium outlet temperature) is optional and has no effect on regulation, it is a readout value only. S4 can however be setup as a Regulation control On / Off switch instead to provide an external ON/OFF function for the controller.

Figure 1: Regulation control

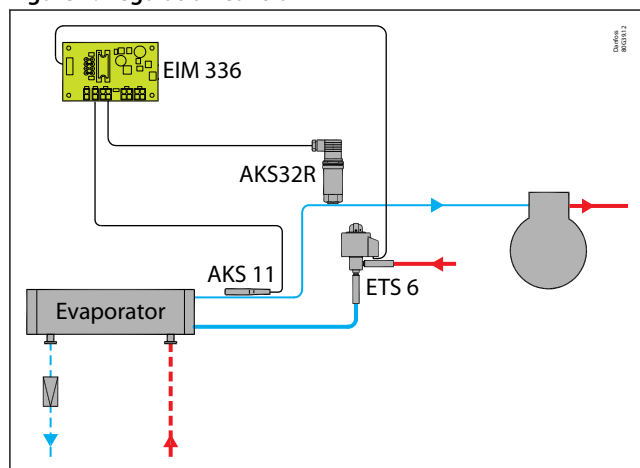

4 Product specification

4.1 Technical data

Table 2: Technical data

Features	Description
Supply voltage	24 V AC / DC (± 15%), 50 / 60 HZ, 15 VA / 8 Watt, Class II isolation
Power consumption	Idle Max. 150 mA @ 24 V DC
	Operating Max. 150 mA @ 24 V DC
Input signals For the EMC compliance, sensor cable length must be < 3m / 118 in. For longer sensor cable, a ferrite bead should be used.	Po AKS 32R (or similar ratiometric pressure transmitter)
	S2 PT1000 (measuring range -60 – +120°C / -76 – 248 °F)
	S4 PT1000 or digital input from external contact.
EEV driver	Max. current 150 mA RMS
EEV	Uni- or bipolar coil with JST XHP-5 connector
Data communication	RS485 – Modbus RTU (Not terminated internally)
Environment	Storage: -34 °C to 71 °C / -30 °F to 160 °F
	Operating: -25 °C to 60 °C / -13 °F to 140 °F
	Humidity: <95% RH, non condensing
Dimensions	25 × 50 × 80 mm / 0.98 × 1.97 × 3.15 inch
Operation	Stand alone or via Modbus data communication

4.2 Connections

Figure 2: Stand alone configuration

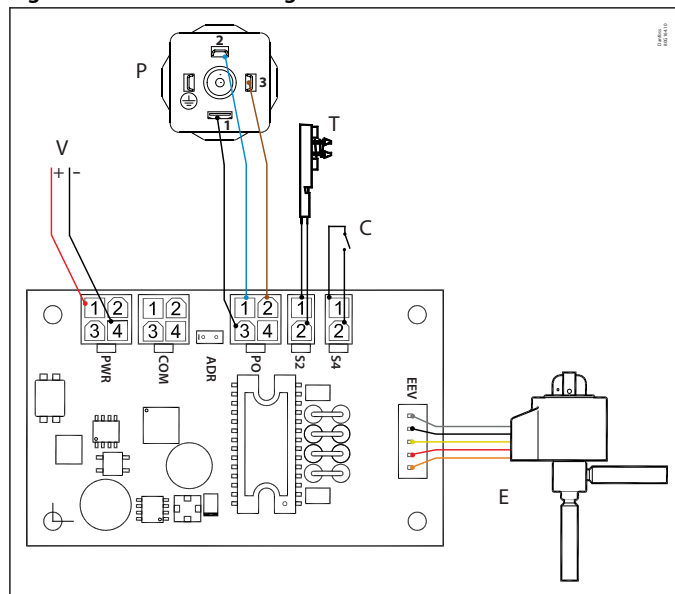

V	Power Supply 24 V AC or DC
P	Pressure transmitter Ratiometric 0.5 – 4.5 V i.e. AKS 32R
T	Temperature sensors PT 1000 i.e. AKS 11
C	Regulation control On/Off switch (Enable parameter HW Main Switch to 1)
E	Electric expansion valve ETS 6 with JST-XHP 5 connector

Superheat controller, Type EIM 336

Figure 3: System configuration (default factory settings)

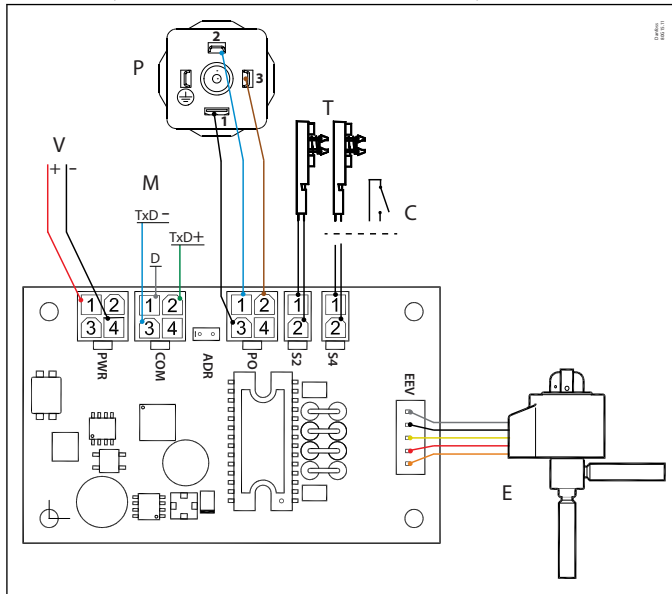

V	Power Supply 24 V AC or DC
P	Pressure transmitter Ratiometric 0.5 – 4.5 V i.e. AKS 32R
M	Modbus to master controller
T	Temperature sensors PT 1000 i.e. AKS 11
C	Regulation control On/Off switch (Enable parameter HW Main Switch to 1)
E	Electric expansion valve ETS 6 with JST-XHP 5 connector

IMPORTANT:

- The supply voltage is not galvanically separated from the input and output signals, hence it is not recommended to use shared power supply.
- No voltage should be supplied externally, if S4 terminal is setup as a Regulation on/off switch.
- Do not reverse the polarity of the power connection cables or Modbus signal cable else it could damage the terminals.

Figure 4: Modbus one to one connection

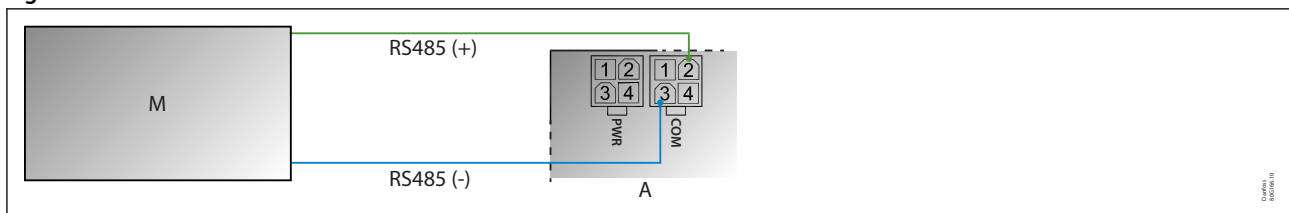
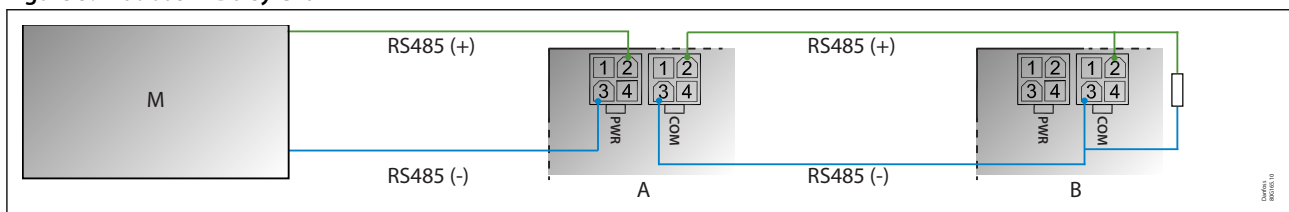

Figure 5: Modbus in Daisy Chain



M	Master controller	B	EIM slave 2
A	EIM slave 1	R	120 Ohm min. 0.25 Watt

NOTE:

- If two EIMs are connected remember to remove the addressing jumper on one of the EIMs.
- Modbus transmission lines usually require termination resistors, especially for longer cable lengths.

4.3 Settings

4.3.1 Setting controller in Superheat control mode

NOTE:

Make sure that r12 = 0 (OFF) and change the settings. The setting will depend on the system requirement.

Table 3: Setting controller in Superheat control mode.

Features	Description
Enabling Regulation control ON/Off switch (optional)	HwMainSwitch = 1 (default is 0, i.e S4 sensor) For standalone configuration it is recommended to enable Regulation control ON/Off switch in order to control start/stop regulation when needed, otherwise the controller will start regulating when controller is powered up.
Select Refrigerant	o30 = 1 - 42 (default value is 20 i.e R407C)
Select valve setting(optional)	n37 = 384 x 10 micro step (3840 micro steps = 480 half steps). n38 = Max. steps/sec, default value is 31 half steps For other valve type than Danfoss check the technical spec. of the valve.
Define pressure sensor range in bar absolute (x10)	o20 = Min. Transducer pressure o21 = Max. Transducer pressure
Define min/max superheat	n10 = min. superheat reference n09 = max. superheat reference For fixed superheat define n09 = n10
Define MOP (optional)	n11 = maximum operating pressure (default is 12.5 bar absolute, max. 200 = MOP off)
Set force opening of the valve (optional)	Start OD% (n17) StartUp time (n15)
To start the superheat control	Set r12= ON

4.3.2 Setting controller in valve driver mode using Modbus signal

NOTE:

Make sure that r12 = 0 (OFF) and change the settings so they fit to their application.

Table 4: Setting controller in valve driver mode using Modbus signal

Features	Description
Select Application mode	o18 (PNU 2075)= 1 i.e Manual control
Select valve setting(optional)	n37 = 384 x 10 micro step (3840 micro steps = 480 half steps). n38 = Max steps/sec, default value is 31 half steps for other valve type than Danfoss check the technical spec of the valve
Select Manual opening degree	o45 Manual OD % (PNU 2064) 0 = fully closed, 100 = fully open.

By changing parameter o45 Manual OD, the valve will move accordingly regardless of r12 parameter value.

4.3.3 Selecting a refrigerant

The controller needs to know which refrigerant is used in order to accurately control the superheat. This can be selected by setting the “o30 Refrigerant” to the desired refrigerant as defined in the list below.

If no refrigerant is selected (“o30 Refrigerant” is set to 0 meaning the refrigerant is undefined), the “No Rfg. Sel.” alarm is set and the controller will not start regulating.

Refrigerant setting

Before refrigeration can be started , the refrigerant has to be defined. You can select the following refrigerant.

Table 5: Related parameters

Symbolic name	PNU	Description
o30 Refrigerant	2551	1 = R12 10 = R503 19 = R404A 28 = R744 37 = R407F
		2 = R22 11 = R114 20 = R407C 29 = R1270 38 = R1234ze
		3 = R134a 12 = R142b 21 = R407A 30 = R417A 39 = R1234yf
		4 = R502 13 = User defined 22 = R407B 31 = R422A 40 = R448A
		5 = R717 14 = R32 23 = R410A 32 = R413A 41 = R449A
		6 = R13 15 = R227 24 = R170 33 = R422D 42 = R452A
		7 = R13b1 16 = R401A 25 = R290 34 = R427A
		8 = R23 17 = R507 26 = R600 35 = R438A
		9 = R500 18 = R402A 27 = R600a 36 = Opteon XP10

WARNING:

Wrong selection of refrigerant may cause damage to the compressor.

4.3.4 Connecting and setting up a valve

The EIM 336 controller is designed to be used with Danfoss ETS 6 valves with a maximum of 480 pulses from fully closed to fully open. This setting should not be changed.

The speed of the valve can be changed by increasing or decreasing the number of pulses per second, “n38 Max StepsSec”. A larger value will make the valve open or close faster. Note that the torque of a stepper motor decreases as the speed increases. Too high speeds should therefore be avoided. For the ETS 6 valve, the recommended speed setting is 31 pulses per second.

When the controller is powered, the valve will first be closed fully so that the controller starts from a known opening degree (0%). In order to make sure that it is fully closed, the valve will be closed 100% plus an additional contribution known as start backlash. The start backlash takes into account that the stepper motor may lose some steps due to too low torque or mechanical slippage in the gears etc. The start backlash is the amount of extra steps in percent to close once the valve is closed (less than 1%). If the valve is opening and reaches its destination, it will move additional steps in the opening direction, then move the same amount of steps in the closing direction. This is called backlash and is the amount of steps to add to compensate for spindle play.

Table 6: Related parameters

Symbolic name	PNU	Description
n38 Max. Steps Sec.	3033	Steps per second
n39 Start BckLsh	3034	Backlash, is the additional amount of steps, in percent, to close at startup and when the valve opening degree is less than 1%.
n40 Backlash	3035	Start Backlash is the amount of steps to compensate for spindle play.

4.3.5 Connecting and setting up a pressure sensor

The pressure sensor input is setup by default to accept an AKS32R pressure transducer. If another sensor is to be used, it is important to note that it needs to be a 0.5 - 4.5 V d.c. ratiometric type (10% - 90% of supply voltage).

The default range for the sensor is 0 to 16 bar absolute. This can be changed by setting the minimum transducer pressure, “o20 MinTransPres” and the maximum transducer pressure, “o21 MaxTransPres” to the new values. The values must be entered in bar absolute so a sensor with a range of -1 to 12 bar gauge, needs to be defined as 0 to 13 bar absolute.

Table 7: Related parameters

Symbolic name	PNU	Description
o20 MinTransPres	2034	Minimum transducer pressure (in bar absolute x 10). Example: 0 bar absolute is entered as 0
o21 MaxTransPres	2033	Maximum transducer pressure (in bar absolute x 10). Example: 13 bar absolute is entered as 130

NOTE:

Both Danfoss AKS 32R and Danfoss Saginomiya Pressure transmitter NSK-BExxx follows the relative (gauge) pressure, therefore same rules applies as explained above in converting and defining it in bar absolute in EIM controller.

Mounting pressure transmitter

Installation of the pressure transmitter is less critical, but mounting of pressure transmitter should be closer to the temperature sensor, right after the evaporator and with its head in upright position.

Power supply:

- Grounding of secondary (output) of transformer is not recommended.
- Do not reverse the polarity of the power connection cables and avoid ground loops (i.e. avoid connecting one field device to several controllers as this may result in short circuits and can damage your device).
- Use individual transformers for EIM 336 controller to avoid possible interference or grounding problems in the power supply.

WARNING:

- Separate the sensor and digital input cables as much as possible (at least 3 cm) from the power cables to the loads to avoid possible electromagnetic disturbance.
- Never lay power cables and probe cables in the same conduits (including those in the electrical panels).

Mounting temperature sensor

Figure 6:

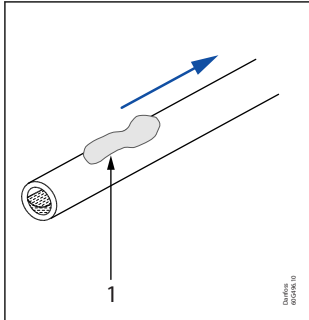

Figure 7:

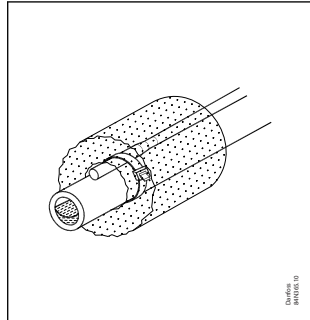
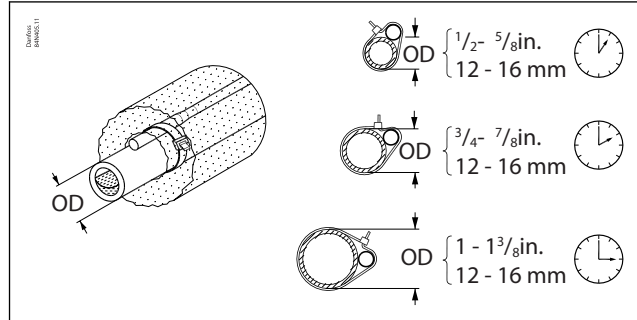

Figure 8:



1 Conductive paste

IMPORTANT:

- Mount sensor on a clean surface without any paints.
- Remember to put on heat conducting paste and insulate the sensor.
- Sensor mounting max. 5 cm from the outlet of the evaporator to get the precise measurements.

Figure 9: Mounting sensor

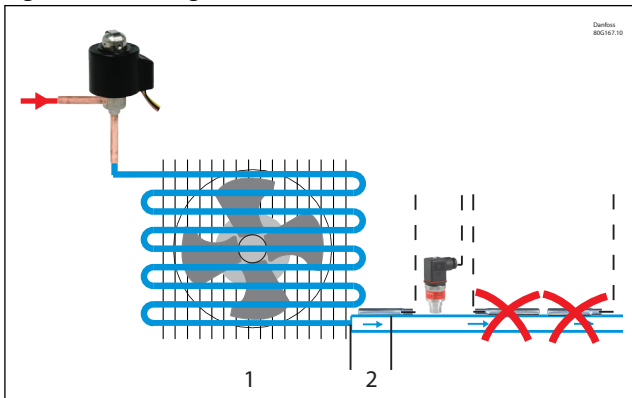

- | | |
|----------|--|
| 1 | Evaporator |
| 2 | sensor mounted close to the evaporator |

4.3.6 Using external sensor values

In some applications, the suction pressure and/or the refrigerant temperature on the evaporator outlet, is measured by a system controller. This is often the case if the suction pressure is used to trigger low temperature/pressure alarms by the systems main controller. In these cases the sensors can be omitted from the EIM 336, and the sensor values can be received via modbus instead. This requires that the systems main controller continuously transmits these values to the EIM 336. If no new sensor value is received within 5 seconds of the last transmission, the sensor will revert to using the physical sensors.

The suction gas temperature S2 and the evaporator pressure Pe can be set by writing to the registers “ext S2 Temp” and “ext EvapPress P0” respectively.

NOTE:

The external evaporator pressure is received in millibar so 8.4 bar absolute must be sent as 8400. It is possible to set the S4 temperature as an external sensor value also, but since this sensor is not used in the superheat regulation, this has little practical use.

Table 8: Related parameters

Symbolic name	PNU	Description
ext EvapPress P0	2643	External evaporator pressure. This value can be used instead of a sensor. This register must be written at least every 5 second, otherwise the sensor value will be used. The entered value is in millibar
ext S2 temp	2644	External S2. This value can be used instead of a sensor. This register must be written at least every 5 second, otherwise the sensor value will be used.
ext S4 air temp.	2646	External S4. This value can be used instead of a sensor. This register must be written at least every 5 second, otherwise the sensor value will be used.

4.3.7 Configuring the superheat control

The superheat control algorithm will attempt to regulate the superheat down to the lowest stable value between the minimum superheat setting, “n10 Min SH” and the maximum superheat setting, “n09 Max SH”. If a fixed superheat reference is desired instead, the “n10 Min SH” and “n09 Max SH” can both be set to the desired reference value. This will disable the minimum stable superheat search algorithm and the controller will instead regulate the superheat according to this reference.

The time constant for the superheat control can be changed by setting “Tn SH”.

The alpha value is the design time constant and should be in reasonable proximity to the time constant of the evaporator. A large alpha value means a slow reaction, a small alpha value means a fast reaction.

If the superheat drops below “n22 SH close”, the controller will close the valve faster to avoid the risk of liquid in the compressors suction line.

Figure 10:

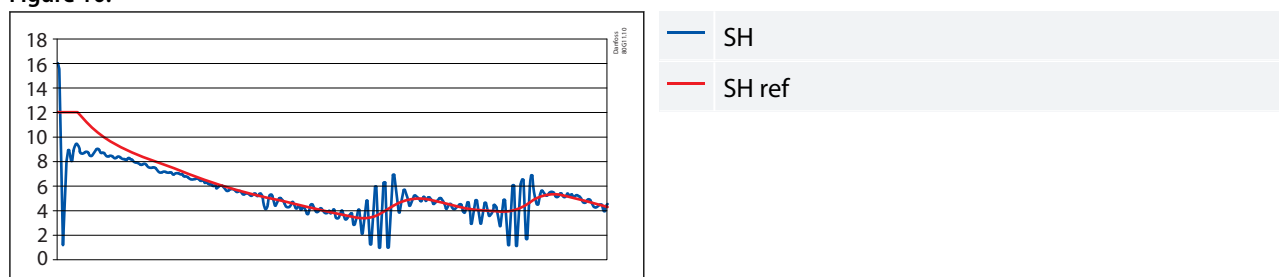

Table 9: Related parameters

Symbolic name	PNU	Description
n09 Max. SH	3015	Maximum superheat reference setting.
n10 Min. SH	3021	Minimum superheat reference setting.
n20 Kp T0	3025	Pressure feedback gain.
n22 SH close	3027	Superheat close level. If the superheat goes below this value, the valve will close faster.
--- Tn SH	3103	Integration time for superheat control
--- Alpha	3111	Design time constant. A large alpha means a slow response, a small alpha mean a fast response.
--- Max. SH shdw	64301	Copy of 3015. If it is required to write n09 frequently, this should be used instead.
--- Min. SH shdw	64302	Copy of 3021. If it is required to write n10 frequently, this should be used instead.
--- Tn SH shdw	64303	Copy of 3103. If it is required to write TnSH frequently, this should be used instead.
--- Alpha shdw	64304	Copy of 3111. If it is required to write alpha frequently, this should be used instead.

NOTE:

Main Switch r12 should be ON to start the regulation. This can also be accomplished with the external Regulation control ON/Off switch. See [Interactions](#) for details.

4.3.8 System configuration

The EIM 336 controller has a default configuration to be operated via modbus and to rely on a constant connection to the master controller of the system it is located within. In this configuration the master controller reads the readout registers from the EIM 336 and uses the parameters to change the control behaviour of the EIM 336 (see [Parameter list](#)).

The following control modes are available:

Superheat controller, Type EIM 336

- Minimum Stable Superheat search (MSS) is the default control mode
- Manual control
- Defrost
- Maximum Operating Pressure control (MOP)
- T_e control (De-humidifying).

Controlling manually via modbus

When setting the manual control register “o18 Manual ctrl.” to 1, the controller will be in manual control. During this mode the opening degree is controlled by setting the “Manual OD%”. The manual control mode does not depend on the “r12 Main Switch”, and will set the opening degree regardless of its setting. Setting “o18 Manual ctrl.” to 0 again, the controller will assume normal control, and will open or close from the current opening degree.

Figure 11: Controlling manually via modbus

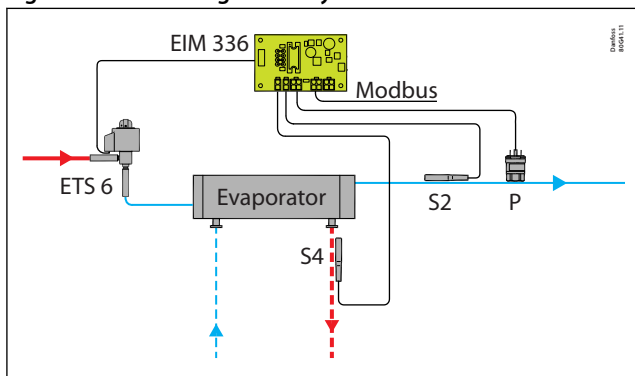

NOTE:

On using system configuration, it is necessary to read the "Ctrl Stats" register 3100 continuously, failure to do so will start the MSS regulation automatically irrespective to the different status of the regulation On / Off switch. Refer Appendix 1 for detail.

Table 10: Related parameters

Symbolic name	PNU	Description
o18 Manual ctrl.	2075	0 = Superheat control, 1 = Manual control
o45 Manual OD%	2064	Manual opening degree in percent. 0 = fully closed, 100 = fully open. Used when the o18 Manual Control is set to 1.

Standalone configuration (no Modbus communication)

The EIM 336 can be set in a standalone configuration by setting the modbus register i.e “HWMMainSwitch” to 1. This will setup the S4 input to be used as a Regulation On / Off switch. Note that only external control of the EIM 336 in this configuration is through the Regulation On / Off switch.

The following control modes are available:

- Minimum Stable Superheat search (MSS) is the default control mode
- Maximum Operating Pressure control (MOP), but the Diff MOP option is not available

The following control modes are not available:

- Manual control
- Defrost
- T_e control (De-humidifying)

Figure 12: Standalone configuration (no modbus communication)

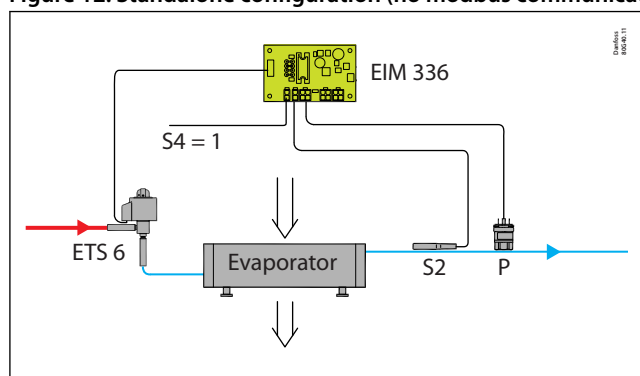

NOTE:

That the only external control of the EIM 336 in this configuration is through the Regulation control On / Off switch. It is not possible to manually control the opening degree or change settings, and the defrost and Te control modes are not available.

Table 11: Related parameters

Symbolic name	PNU	Description
--- HWMainSwitch	64100	0 = no external main switch 1 = regulation control On / Off switch

4.3.9 MODBUS Communication

Setting up modbus parameters

The modbus baud rate, “Modbus Baud”, can be set to three different baud rates. The modbus parity “ModbusParity” can be set to either no parity, odd parity or even parity. The modbus stop bit can be set to either 1 or 2 stop bits. The default settings are 19200 baud, even parity and 1 stop bit.

A jumper KM7 has been added to the EIM 336, for selecting between two predefined addresses. This is useful for applications such as reversible air conditioning/heat pump systems with both an indoor and an outdoor unit. In this way the address can be changed without the need to reconfigure the controllers settings. The primary unit address “o03 Unit addr.” is used when the jumper is mounted. The secondary unit address “Unit Addr. 2” is used when the jumper is not mounted. The default primary address is 165, the default secondary address is 164.

NOTE:

Changes to these parameters will become active immediately. This means that a modbus tool or controller that changes these settings will loose connection to the EIM 336 and will need to reestablish connection using the new settings.

The EIM 336 “read holding registers” function (0x03) is limited to a maximum of 20 consecutive registers per read request. If a modbus tool or a controller is used to read parameters over modbus, it needs to take this into account.

During the communication the transmitted Modbus requests are checked for CRC errors. If the CRC is not correct, the request is discarded and the EIM 336 waits for a new request. In this case no exception response is issued.

Loss of communication

The EIM will expect that a master controller reads the status register (PNU 3100) at least every 30 seconds or more often. If this does not happen the controller will switch to stand-alone control mode. Without communication it will assume it is ON, and it will disregard the current status of the SW main switch (PNU 117). Under normal conditions it will control the superheat by adjusting the opening degree based on the sensor inputs.

NOTE:

The 30 second timer is reset every time the status register is read by the master controller. if communication is loss when the controller was in manual control, then it will remain in manual control, and keep its current opening degree regardless of superheat.

Table 12: Related parameters

Symbolic name	PNU	Description
o03 Unit addr.	2008	Primary unit address is used when jumper KM7 is mounted
--- Unit Addr. 2	2009	Secondary unit address is used when the jumper KM7 is not mounted
--- Modbus Baud	50060	Communication setting baud rate, 0 = 9600, 1 = 19200, 2 = 38400
--- ModbusParity	50061	Communication setting parity, 0 = no parity, 1 = odd parity, 2 = even
--- ModbusStopB	50062	Communication setting stop bit, 1 = 1 stop bit, 2 = 2 stop bit

For detailed explanation and examples, please refer to manual 'EKD EIM Data communication Modbus RS485 RTU'

Connecting Modbus

- For the modbus cable, it is best to use 24AWG shielded twisted-pair cable with a shunt capacitance of 16 pF/ft and 100Ω impedance.
- The max. permissible number of devices simultaneously connected to RS485 output is 32. The RS485 cable is of impedance 120 Ω with maximum length of 1000 m.
- Terminal resistors 120 Ω for terminal devices are recommended for length > 1 m.

Figure 13: Connecting Modbus

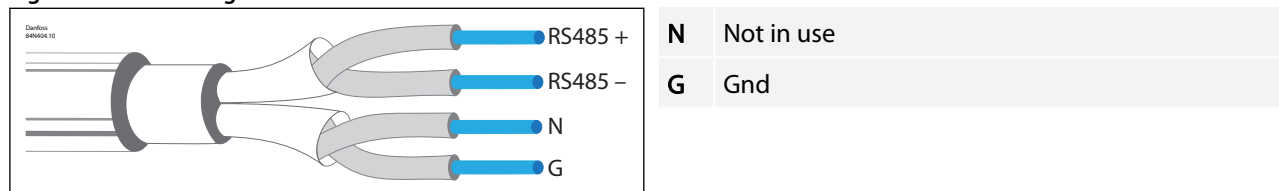

Detail explanation on Modbus installation and software parameter setting can be found in User guide: DATA COMMUNICATION MODBUS RS 485 RTU

⚠ WARNING:

- Accidental damage, poor installation, or site conditions, can give rise to malfunctions of the control system, and ultimately lead to a plant breakdown.
- Every possible safeguard is incorporated into our products to prevent this. However, a wrong installation, for example, could still present problems. Electronic controls are no substitute for normal, good engineering practice.
- Danfoss will not be responsible for any goods, or plant components, damaged as a result of the above defects. It is the installer's responsibility to check the installation thoroughly, and to fit the necessary safety devices.
- Particular attention is drawn to the need for a "force closing" signal to controllers in the event of compressor stoppage, and to the requirement for suction line accumulators.

4.3.10 Using the MOP

In order to reduce the current to the compressor it is possible to control the maximum operating pressure of the evaporator. If the evaporator pressure exceeds the "MOP" limit, the valve opening degree is controlled by the MOP function which will keep the pressure below the "MOP" limit. This function takes precedence over the superheat control, so during MOP control the superheat is not controlled.

The MOP function can be disabled by setting the "MOP" to the maximum value (2000 equalling 200 bar absolute). When the pressure reaches the set MOP point, an increase in OD is restricted. If the pressure reaches MOP + 0.5 Bar, an increase in OD is prohibited, and instead the OD will start to decrease. If the pressure goes below the MOP point, the controller will start to regulate the superheat normally.

The MOP controller consists of a separate PI control, which settings can be changed by setting "Kp MOP" and "Tn MOP". A large Kp will lead to a large change in opening degree even at small changes in the evaporator pressure, but may lead to instability. A large Tn will lead to a slow reacting system, while a small Tn will lead to a fast reacting system.

Figure 14: MOP controlling

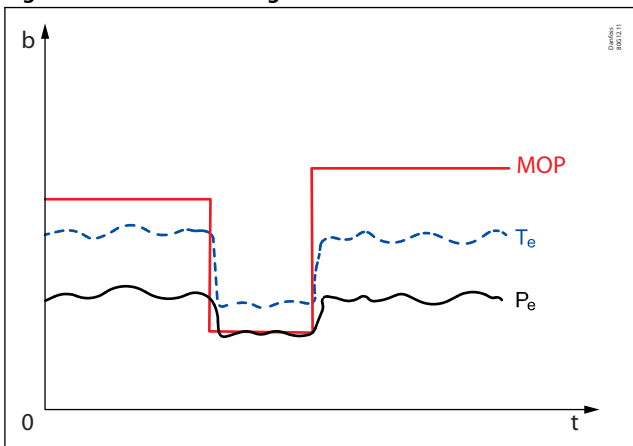

b	bar
t	Time

Figure 15: MOP disabling

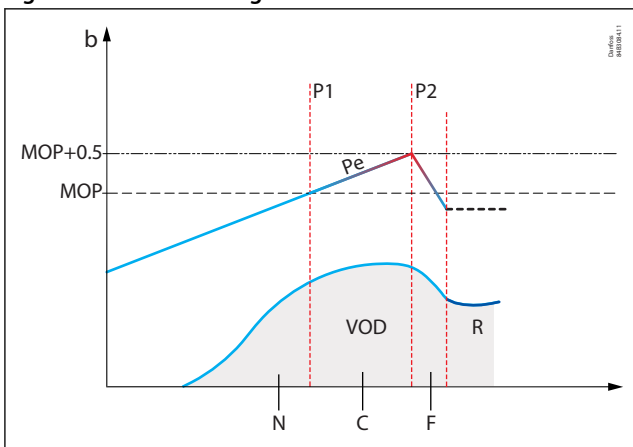

P1	At this pressure the OD increases slower and slower.
P2	At this pressure the OD no longer increases. Beyond it the OD decreases.
Pe	pressure
VOD	Valve Opening Digree
R	Normal regulation
N	Normal OD
C	Controlled OD
F	Force closed OD

Table 13: Related parameters

Symbolic name	PNU	Description
n11 MOP	3013	Maximum operation pressure. If Pe goes above this value, the controller will control on Pe, and not on superheat.
--- Kp MOP	3113	Kp proportional gain while in MOP control mode.
--- Tn MOP	3114	Tn integration time while in MOP control mode.

4.3.11 Using Te control

For applications with a need to de-humidify the evaporator, it is possible to control on the saturated evaporator temperature instead of the normal control signal. If the “Te Reference” register is set to a value above 0, Te control is activated. Te and the Te reference are used by the controller to calculate a new opening degree.

The Te control consists of a separate PI control, which settings can be changed by setting the gain, “Kp Te” and time constant, “Tn Te”. A large Kp will lead to a large change in the output even at small changes in the evaporator temperature, but may lead to instability. A large Tn will lead to a slow reacting system, while a small Tn will lead to a fast reacting system.

The MOP function is still active during Te control and it will assume control, if the evaporator is above the “MOP” limit. The SH close function is also active during Te control and will assume control if the SH is below the SH close limit.

Figure 16: Using T_e control

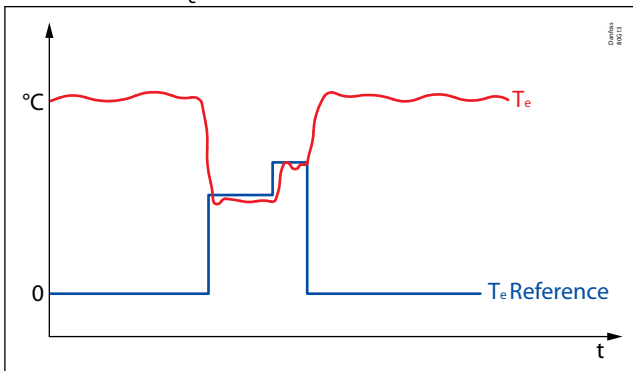

Table 14: Related parameters

Symbolic name	PNU	Description
--- Kp T_e	3115	Kp proportional gain while in T_e control mode
--- Tn T_e	3116	Tn integration time while in T_e control mode
--- T_e Reference	3117	T_e reference while in T_e control mode

4.3.12 Defrosting

A defrost sequence is initiated by setting the defrost activate register “Def Activate” to 1. As long as this register is kept at 1, the valve opening degree is 100%. When “Def Activate” returns to 0, the valve opening degree is kept at “Def Hold OD” for “Def Hold Ti 1” seconds. When this time expires, the valve opening degree is set to a calculated average opening degree (PNU 50021) for “Def Hold Ti 2” seconds. When this time expires the controller resumes normal operation.

The average opening degree is calculated as an average of the last hour while operating in injection state. Other states such as manual control, defrosting or if the valve is fully closed are not included in the calculation of the average.

Figure 17: Defrosting

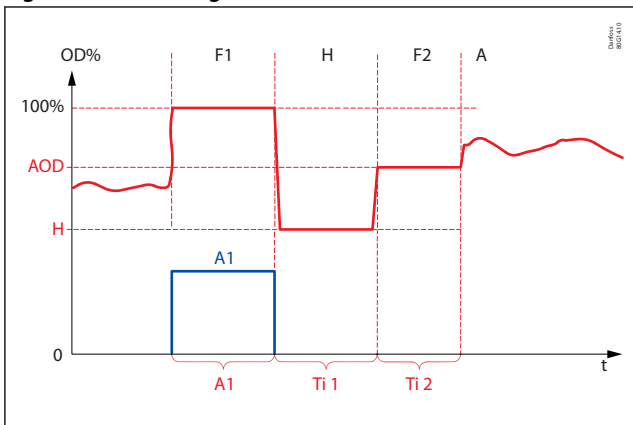

OD%	Opening degree in percentage
t	time
AOD	Avg. OD
H	Def Hold OD%
F1	Fixed 100 OD%
F2	Fixed Avg.OD%
A	Auto control
A1	Defrost activate = 1
Ti 1	Def Hold time 1
Ti 2	Def Hold time 2

NOTE:

- Defrost is not initiated by the EIM 336, but must be initiated by the master controller. In a standalone configuration the defrost mode is not possible.
- If a more dynamic control of the opening degree during defrost is required, the user should disable the “Def Hold Ti 2” by setting it to 0, and only use the “Def Hold Ti 1”. If frequent changes are to be made to the “Def Hold OD”, the parameter “DefHold shdw” should be used instead. This parameter is an exact copy of the “Def Hold OD” except that it is not placed in the Eeprom.
- If the communication is lost when the controller was in the process of defrosting, this process will continue. When the entire sequence is completed it will go to superheat control. However, if the defrost activate signal was set (50011), it will go to 100% opening. If it is never cleared, the sequence will stop, and it will stay fully open.

Table 15: Related parameters

Symbolic name	PNU	Description
--- Def. Activate	50011	Defrost activating, 0 = no defrost, 1 = defrost active
--- Def. Hold OD	50008	Opening degree during Def Hold Ti 1
--- Def. HoldTi 1	50009	Defrost hold time 1
--- Def. HoldTi 2	50010	Defrost hold time 2
--- DefHold shdw	64305	Copy of 50008. If it is required to write Def Hold OD frequently, this should be used instead.

4.3.13 LOC detection

When a system loses refrigerant charge the controller will have difficulties keeping the superheat low, even when increasing the valve opening degree. Therefore, if both the valve opening degree and the superheat are high for a long period of time, this could indicate that refrigerant charge was lost.

When the valve opening degree exceeds the trigger level "LOC Trig, and the superheat exceeds the superheat trigger level "LOC SH Trig", a timer is started.

When the timer exceeds the user defined time "LOC Timer" the "LOC Alarm" is set. If the valve opening degree drops below the user defined reset level "LOC Reset", the timer and the alarm are reset.

The loss of charge alarm does not perform any actions, except setting the "LOC Alarm".

Table 16: Related parameters

Symbolic name	PNU	Description
--- LOC Trig	50003	Trigger value for loss of charge
--- LOC Reset	50004	Reset value for loss of charge
--- LOC Timer	50005	Timer to trigger LOC alarm
--- LOC Alarm	50006	Loss of charge alarm flag, 0 = no alarm, 1 = LOC alarm
--- LOC SH Trig	50007	SH error trigger level for LOC alarm
--- LOC Tmr	3102	Loss Of Charge time readout displays the elapsed time since the alarm became active.

4.3.14 Finding the optimum settings

Details on the controller algorithm and settings

Problems with startup

Sometimes in one-to-one applications, the valve does not open sufficiently on startup, and troublesome low pressure trips may occur.

The force opening of valve function has been implemented in the EIM 336 controller. After startup, this function will provide a constant, set minimum opening degree during a set time period, regardless of the superheat value. The setting parameters are called Start OD% (n17) and StartUp time (n15).

Figure 18: Forced opening of valve

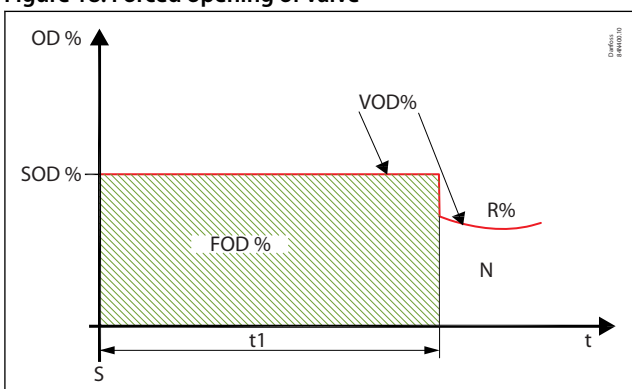

SOD%	Start OD%
FOD%	Forced OD%
N	Normal Reg.
R%	Reg. OD%

Low Pressure Issue due to compressor cut in and cut out

One of the features of TEX valves is the external pressure equalization making a direct and fast responding pressure connection between the compressor suction line and underside of the diaphragm in the valve. This enables the valve to open-/ close momentarily with compressor capacity cut in and out.

The same function has been implemented into EIM 336, which is controlled by the parameter n20, KpTo. In this function. kp factor related directly to the suction pressure (To) with direct effect on the requested signal to the ETS 6 valve .

The default value of KpTo is set to automatic (i.e -1). If the automatic tuning is not fulfilling the desired order, Increasing the n20 setting to the fixed value will contribute to an improvement. Too high n20 will produce high fluctuation in superheat regulation.

Fluctuating superheat

When the refrigerating system has been made to work steadily, the controller's factory-set control parameters should in most cases provide a stable and relatively fast regulating system. If the system however fluctuates, this may be due to the fact that too low superheat parameters have been selected or due set of regulation parameters which are not optimal.

Usually, the following parameters can be tuned in order to reach fast, stable superheat in EIM controller.

1. If adaptive superheat has been selected adjust n09 and n10 parameters. For some application using fixed superheat may increase the stability. This can be done by defining n09 and n010 to the fixed value.
2. To optimize the superheat regulation, most safe and direct way is to tune TnSH. For example, if a the control is too slow, define new Tn value to half ($1/2 Tn$), if it is still slow reduce it to another half ($1/2 \times 1/2 Tn = 1/4 Tn$), If the control start to oscillation, then return back to ($\sim 3/8 Tn$) , alternatively read the time period and tune $tn = 1.2 \times$ time period.
3. Keep KpT0, Alpha as default, they work for most of the cases.
4. Tune parameter for force opening of the valve at start up i.e. n15 (startup OD) and n17 (start up time). These values depends on the system conditions.

i NOTE:

Steps (1.) to (3.) are quite easy and safe to tune. For step (4.), caution should be taken, so as not to allow refrigerant inside the compressor.

Too high fluctuating pressure signal

1. Tune parameter n20 KpT0 to lower value, if this is not working for the system disable by setting it to zero.
2. If point 1 doesn't seem to be working, then keep n20 KpT0 disable and increase para TSH (i.e Tan SH). Increase TSH (default value) by 200 and check the oscillation. If the problem seems to persist, perform the same step up to higher TSH value.

4.3.15 Alarms and clearing alarms

Several alarms are registered and made available on modbus. Most of these are automatically cleared when the error is no longer present.

Sensor error : Temperature sensor error has a timeout of 10 minutes. This means that after the reason for a sensor error has gone, the error will remain active for 10 minutes, and then it is cleared. for the pressure sensor, the timeout is only 30 seconds.

There is an option to reset the errors externally by setting the 40075 (reset alarms) = 1.

Table 17: Related parameters

Symbolic name	PNU	Description
--- Reset alarm	2046	1 = Clear alarm. It is possible to clear alarms manually by setting Reset Alarms (40075). After setting this, the alarm is kept active for 5 seconds before being cleared.
--- EKC Error	20001	Common error flag. EKC Error is SET if any other Error Alarm is ON. EKC error is auto cleared after the last active alarm has been cleared.
--- S2 Error	20002	S2 sensor error. If the sensor error occurs, the valve OD will be set to 80% of the Avg. opening (PNU 50021) - see Troubleshooting . S2 alarm is auto cleared after 10 min after the alarm condition has been cleared.
--- S4 Error	-	S4 is not monitored
--- Pe inp.error	20005	Pressure transmitter out of range. If the sensor error occurs, the valve OD will be set to 80% of the Avg. opening (PNU 50021) - see Troubleshooting . Pe alarm is auto cleared after 30 seconds.
--- No Rfg. Sel.	20006	Refrigerant not selected. No Refrigerant selected alarm is auto cleared immediately after setting the refrigerant.
--- LOC Alarm	50006	Loss of charge alarm. No action will be performed except setting the alarm.
--- Ctrl Status	3100	Bit mapped status register, see also Control status

4.3.16 Troubleshooting

Table 18: Troubleshooting

Symptom	Possible Cause	Remedy
Suction pressure too low	Pressure drop across the evaporator too high	-
	Lack of subcooling ahead of expansion valve	Check refrigerant ahead of expansion valve. If the valve is placed much higher than condenser outlet, check pressure difference.
	Evaporator superheat too high	1. Check superheat performance, the settings SH min and SH max. 2. Check valve capacity. 3. Check that the maximum number of steps of valve is same as parameter n37.
	Pressure drop across the expansion valve less than valve is sized for	Check pressure drop across expansion valve. Replace with larger valve.
	Expansion valve too small	Check refrigeration system capacity and compare with expansion valve capacity. Replace with larger valve if necessary.
	Expansion valve block with foreign material	Remove valve and examine the orifice.
	Evaporator wholly or partly iced up	De-ice evaporator
Liquid hammer in compressor	Superheat of expansion valve too low	Increase the values of SH close and SH min.
	Superheat reference set too low	Increase the value of SH min
	The S2 sensor not in good contact with the suction line	Ensure that S2 sensor is secured on suction line. Insulate sensor.
S2 sensor error: PNU 20002	Bad connection or damaged S2 sensor	The controller will go to either the low or high boundary depending on the error. The lowest value will be shown at a short circuit. The highest value will be shown for a missing connection. Check the temperature sensors.
AKS32R out of range: PNU 20005	The suction pressure is above the maximum limit or below the minimum limit	The controller will go to either the low or high boundary depending on the error. The highest value will be shown if the signal is above the maximum value. The lowest value will be shown if the signal is below the minimum value or for a missing connection. Check the pressure range.
LED blinks during operation	No Modbus connection to master controller. (Controller entered autonomous control mode, and it will try to control on its own if possible, or close if no sensor signals are available).	Check Modbus connections between Master controller and the EIM controller. Check the Modbus parameter setting in the controller.

4.3.17 Parameter list

Table 19: Parameter list legend

Row text	Explanation
PNU	The Parameter Number in the EIM 336 controller. All parameters are addressed as holding register. The Modbus PDU address corresponds to PNU-1. If no translation table is used, this is the register number in modbus.
Min.	Minimum value
Def.	Factory default value
Max.	Maximum value
e2	Is the value stored in EEPROM
W	Is writing to the register possible

Superheat controller, Type EIM 336

Row text	Explanation
*10	The scaling of the parameter. All values are read/written as integers over modbus. Parameters need to be scaled, these are marked with a checkmark. This means that 0.1 is sent as 1 over modbus, 1.0 is sent as 10 etc.
Symbolic name	The name of the parameter
Description	Short parameter description

i NOTE:

Some parameters have what is called a "config lock". This means that they can only be changed when the main switch of the EIM 336 is set to OFF (r12 = 0). This applies for instance to the type of refrigerant (o30). So if you want to change the refrigerant, the main switch (r12) must first be set to 0, then the refrigerant type (o30) can be changed.

The following parameters require the main switch (r12) to be OFF:

- n37 Max steps
- n38 Max steps/sec
- o03 Unit address
- o30 Refrigerant

Please refer to the list below. It should be possible to change all other parameters while the unit is running (regulation parameters etc.).

Shdw (*): Shdw values are stored in the volatile memory and will revert back to the previously stored value in its main parameter if the power failure occurs. Altering the main parameter will automatically change the shdw value. If frequent change in parameter required, it is recommended to use shdw parameter.

Table 20: Parameter list

Group	PNU	Parameter	Symbolic name	Min.	Max.	Default	Units	e2	W	*10	Description
Regulation Control	117	r12	Main switch	0	1	0	-	-	✓	-	Start/stop of regulation. With this setting the regulation can be started and stopped. This can also be accomplished with the external hardware main switch. See also Interactions
	2075	o18	Manl control	0	1	0	-	-	✓	-	0 = Superheat control, 1= Manual control
	2064	o45	Manual OD	0	100 / 480	0	% / step	-	✓	-	Manual opening degree for manual control . Used when the o18 Manual Control is set to 1. 0%/0 step = fully closed, 100%/480 step = fully open. % is chosen by default. See PNU 64309 for changing to step.
	3017	n15	Startup time	0	1000	0	s	✓	✓	-	Time for startup state (in seconds)
	3012	n17	Startup OD	0	100	0	%	✓	✓	-	Opening degree during startup state
	64308	OOD	OD while OFF	0	100	0	%	✓	✓	-	Opening degree during Off state

Superheat controller, Type EIM 336

Group	PNU	Parameter	Symbolic name	Min.	Max.	Default	Units	e2	W	*10	Description
Super Heat Control	3015	n09	Max. superheat	2	50	16	K	✓	✓	✓	Maximum superheat reference setting
	3021	n10	Min. superheat	1	50	4	K	✓	✓	✓	Minimum superheat reference setting
	3025	n20	KpT0	-1	20	-1	-	✓	✓	✓	Pressure feedback gain Automatic = -1, OFF = 0, Fixed = 1 and above
	3027	n22	SH close	0	16	0.5	K	✓	✓	✓	Superheat close level. If the superheat goes below this value, the valve will close faster
	3103	TSH	Tn SH	10	1800	600	-	✓	✓	-	Tn integration time for the superheat control. Lower value give fast regulation response. Very low value give the risk of unstable regulation.
	3105 ⁽¹⁾	SHL	SH Low	3	50	6	K	✓	✓	✓	Superheat low setting for non-linear control
	3106 ⁽¹⁾	SHH	SH High	8	50	16	K	✓	✓	✓	Superheat high setting for non-linear control
	3107 ⁽¹⁾	GaH	Gain High	0.5	50	1	-	✓	✓	✓	Expected gain at SH high for non-linear control
	3108 ⁽¹⁾	GaL	Gain Low	0.1	50	12.5	-	✓	✓	✓	Expected gain at SH low for non-linear control
	3109 ⁽¹⁾	TaH	Tau High	10	600	45	-	✓	✓	-	Expected tau at SH high for non-linear control
	3110 ⁽¹⁾	TaL	Tau Low	10	600	110	-	✓	✓	-	Expected tau at SH low for non-linear control
	3111	Aph	Alpha	15	600	130	-	✓	✓	-	Design time constant. A large alpha means a slow response, a small alpha mean a fast response.
	3120	CoS	Comp Speed	0	100	0	%	-	✓	✓	Compressor speed $Tn=2x Tn$ if compressor speed is set to 0% $Tn=Tn$ if the compressor speed is set between 25 - 100% - ref. parameter 3103
	64301	n09x	Max. superheat shdw	2	50	16	K	-	✓	✓	Copy of 3015. If it is required to write Max superheat frequently, this should be used instead
	64302	n10x	Min. superheat shdw	1	50	4	K	-	✓	✓	Copy of 3021. If it is required to write Min superheat frequently, this should be used instead
64303	TSHx	Tn SH shdw	10	1800	600	-	-	✓	-	Copy of 3103. If it is required to write TnSH frequently, this should be used instead.	
64304	Aphx	Alpha shdw	15	600	130	-	-	✓	-	Copy of 3111. If it is required to write alpha frequently, this should be used instead.	
MOP	3013	n11	MOP	0	200	13.7	bar (abs.)	✓	✓	✓	Maximum operation pressure. If Pe goes above this value, the controller will control on Pe, and not on superheat
	3113	KpM	Kp MOP	0.5	10	0.5	-	✓	✓	✓	Kp proportional gain while in MOP control mode
	3114	TnM	Tn Mop	30	600	180	-	✓	✓	-	Tn integration time while in MOP control mode
	3121	DMO	Diff MOP	-20	0	0	bar (abs.)	-	✓	✓	Differential MOP. A remote offset that is added to the MOP. Needs to be written every 5 seconds, else the offset is set to 0.
Defrost	50011	DeA	Def Activate	0	1	0	-	-	✓	-	Defrost activating
	50008	DHO	Def Hold OD	0	100	30	%	✓	✓	-	Defrost holding level
	50009	DH1	Def Hold Ti 1	0	32000	120	s	✓	✓	-	Defrost holding timer 1
	50010	DH2	Def Hold Ti 2	0	32000	60	s	✓	✓	-	Defrost holding timer 2
	64305	DDO	Def hold OD shdw	0	100	30	%	✓	✓	-	Copy of 50008. If it is required to write Def Hold OD frequently, this should be used instead.
T _e Control	3115	KpTe	Kp Te	0.5	10	1	-	✓	✓	-	Kp proportional gain while in Te control mode
	3116	TnT	Tn Te	30	600	60	-	✓	✓	-	Tn integration time while in T _e control mode
	3117	TeR	Te Reference	-200	200	0	°C	-	✓	✓	Te reference while in Te control mode
External sensors	2643	PEV	ext. EvapPress P0	0	65535	0	milli bar	-	✓	-	External evaporator pressure. This value can be used instead of a sensor. This register must be written at least every 5 seconds, otherwise the sensor value will be used.
	2644	TS2	ext. S2 temp	-200	200	0	°C	-	✓	✓	External S2. This value can be used instead of a sensor. This register must be written at least every 5 seconds, otherwise the sensor value will be used.
	2646	TS4	ext. S4 Air temp	-200	200	0	°C	-	✓	✓	External S4. This value can be used instead of a sensor. This register must be written at least every 5 seconds, otherwise the sensor value will be used.
LOC	50003	LTR	LOC Trig	0	100	95	%	✓	✓	-	Trigger value for loss of charge
	50004	LRe	LOC Reset	0	100	85	%	✓	✓	-	Reset value for loss of charge
	50005	LTm	LOC Timer	0	7200	3600	s	✓	✓	-	Timer to trigger LOC alarm
	50007	LST	LOC SH Trig	0	50	20	K	✓	✓	✓	SH error trigger level for LOC alarm

Superheat controller, Type EIM 336

Group	PNU	Parameter	Symbolic name	Min.	Max.	Default	Units	e2	W	*10	Description
Modbus	2008	3	Unit Addr	1	240	165	-	✓	✓	-	Primary unit address is used when jumper KM7 is mounted
	2009	UA2	Unit Addr 2	1	240	164	-	✓	✓	-	Secondary unit address is used when the jumper KM7 is not mounted
	50060	MBa	MB Baud	0	2	1	-	✓	✓	-	Communication setting baud rate, 0 = 9600, 1 = 19200, 2 = 38400
	50061	MPa	MB Parity	0	2	2	-	✓	✓	-	Communication setting parity, 0 = no parity, 1 = odd parity, 2 = even
	50062	MSB	MB StopB	1	2	1	-	✓	✓	-	Communication setting stop bit, 1 = 1 stop bit, 2 = 2 stop bit
	64200	-	Modbus trans	0	3	1	-	✓	✓	-	1 = Enabling translation tables. If the translation table is enabled, only registers some are accessible.
Valve	3032	n37	Max steps	100	1000	384	-	✓	✓	-	Maximum number of steps (384 x 10 microsteps = 480 half steps)
	3033	n38	Max steps/sec	5	300	31	-	✓	✓	-	Steps per second
	3034	n39	Start backlash	1	100	10	%	✓	✓	-	Backlash (steps) to close in percent at startup (power on).
	3035	n40	Backlash	0	100	20	%	✓	✓	-	Backlash (steps) for spindle play compensation. This is active during normal control
	3037	n42	Comp. dir.	1	2	1	-	✓	✓	-	Compensation direction
	3051	n56	Motor current	0	300	150	mA	✓	✓	-	Motor current
Refrigerant	2551	o30	Refrigerant	0	42	23	-	✓	✓	-	1 = R12 15 = R227 29 = R1270 2 = R22 16 = R401A 30 = R417A 3 = R134a 17 = R507 31 = R422A 4 = R502 18 = R402A 32 = R413A 5 = R717 19 = R404A 33 = R422D 6 = R13 20 = R407C 34 = R427A 7 = R13b1 21 = R407A 35 = R438A 8 = R23 22 = R407B 36 = Opteon XP10 9 = R500 23 = R410A 37 = R407F 10 = R503 24 = R170 38 = R1234ze 11 = R114 25 = R290 39 = R1234yf 12 = R142b 26 = R600 40 = R448A 13 = User def. 27 = R600a 41 = R449A 14 = R32 28 = R744 42 = R452A
	2548	RF1	Rfg. fac. A1	8000	12000	10428	-	✓	✓	-	Adiabatic constant A1
	2549	RF2	Rfg. fac. A2	-4000	-1000	-2255	-	✓	✓	-	Adiabatic constant A2
	2550	RF3	Rfg. fac. A3	1000	3000	2557	-	✓	✓	-	Adiabatic constant A3
	113	r09	Adjust S2	-10	0	0	K	✓	✓	✓	S2 Offset adjustment to correct the sensor signal due to long wires etc.
Sensors	2033	o21	Max. transducer pressure	1	200	16	bar (abs.)	✓	✓	✓	Maximum transducer pressure (in bar absolute * 10)
	2034	o20	Min. transducer pressure	0	1	0	bar (abs.)	✓	✓	✓	Minimum transducer pressure (in bar absolute * 10)
	50020	-	Avg KT0 time	10	3600	180	-	✓	✓	-	Average time for KT0 used as filter value for the average opening degree calculation when calculating the KT0
System	50021	-	Avg OD 3 hours	0	1000	100	per mill	✓	✓	✓	Average OD, updated and saved every 3 hours. After power up the last saved average OD is used as starting average OD
	50051	-	Sampling time	1	10	1	sec.	✓	✓	-	Algorithm sampling time
	64200	LBO	Limited list	0	1	0	-	✓	✓	-	Modbus translation table for limited list of sequential registers
	64100	HWM	HW main switch	0	1	0	-	✓	✓	-	1 = S4 input is HW Main Switch
	64309	-	Manual OD as steps	0	1	0	-	✓	✓	-	Enable the manual OD in o45 to be entered as half-steps. Readouts are still in percent
Alarm	2046	RAL	Reset alarm	0	1	0	-	-	✓	-	1 = clear alarm
	20001	-	EKC Error	0	1	0	-	-	-	-	Common error flag. EKC Error is SET if any other Error Alarm is ON.
	20002	-	S2 Error	0	1	0	-	-	-	-	S2 sensor error. If the sensor error occurs, the valve OD will be set to 80% of the Avg. opening (PNU 50021) - see Troubleshooting .
	20005	-	Pe inp.error	0	1	0	-	-	-	-	AKS 32R out of range. If the sensor error occurs, the valve OD will be set to 80% of the Avg. opening (PNU 50021) - see Troubleshooting .
	20006	-	No Rfg. Sel.	0	1	0	-	-	-	-	Refrigerant not selected
	50006	-	LOC Alarm	0	1	0	-	-	-	-	Loss of charge alarm. No action will be performed except setting the alarm.

Superheat controller, Type EIM 336

Group	PNU	Parameter	Symbolic name	Min.	Max.	Default	Units	e2	W	*10	Description
Readout	2531	u16	S4 air temp	-200	200	0	°C	-	-	✓	S4 temperature in °C measured with PT 1000 sensor connected to KM2
	2535	u22	Superheat Ref	0	100	0	K	-	-	✓	Current superheat reference
	2536	u21	Superheat	0	100	0	K	-	-	✓	Current superheat (S2 - evaporator temperature)
	2537	u20	S2 Temp	-200	200	0	°C	-	-	✓	S2 temperature in °C measured with a PT 1000 sensor connected to KM1.
	2542	u24	opening %	0	100	0	%	-	-	-	Actual opening degree
	2543	u25	Evap Press Pe	-200	200	0	bar (abs.)	-	-	✓	Evaporator pressure measured with ratiometric pressure transmitter at KM6.
	2544	u26	Evap Temp Te	-200	200	0	°C	-	-	✓	Evaporator temperature (converted from evaporator pressure)
	3101	-	Closed valve T	0	2000	0	-	-	-	-	Closed valve timer
	3102	-	LOC Tmr	0	2000	0	-	-	-	-	Loss Of Charge time
	50033	-	Avg opening	0	100	0	%	-	-	-	Average opening degree. If it has never run before it will give the value of PNU 50021 at start up.
64306	-	SWVer shdw	x	x	x	-	-	-	-	Copy of 2003. This displays the version number in a non-EKC format. For example 123 means vers 1.23	
Control status	3099	-	Control State	0	5	-	-	-	-	-	Current state of internal control state machine.
	3100	-	Ctrl Status	0	20000	-	-	-	-	-	Bit mapped status register. See also Control status .

⁽¹⁾ For Danfoss only!

4.3.18 Interactions

Interaction between internal and regulation On/Off switch.

Table 21: Parameter HWMMainSwitch (PNU 64100) = 0

Regulation Control on/off switch	r12	Result	SH control	Alarm handling
off (open)	off (0)	=	off	off
off (open)	on (1)	=	on	on
on (closed)	off (0)	=	off	off
on (closed)	on (1)	=	on	on

Table 22: Parameter HWMMainSwitch (PNU 64100) = 1

Regulation Control on/off switch	r12	Result	SH control	Alarm handling
off (open)	off (0)	=	off	off
off (open)	on (1)	=	off	off
on (closed)	off (0)	=	on	on
on (closed)	on (1)	=	on	on

4.3.19 Control status

Table 23: bit 0-15 Variables / parameters

Bit 15	Bit 14	Bit 13	Bit 12	Bit 11	Bit 10	Bit 9	Bit 8	Bit 7	Bit 6	Bit 5	Bit 4	Bit 3	Bit 2	Bit 1	Bit 0
Unused						MOP Active	Close Timer active	Sensor Errors				Control state			
Variables / parameters															
bit 10...15: unused						bit 9 : MOP bit 9 : MOP active.	bit 8 : Close timer bit 8 : timer active	bit 4 ...7: Sensor Errors bit 4 : Te error (pressure sensor error) ⁽¹⁾ bit 5 : S2 error bit 6 : S4 error, (not active) bit 7 : (not active) For detail check Alarms and clearing alarms				CTRLstatus : bit 0...3 : Controlstate 0: Closed (Main switch is off) 1: Error (Main switch is on and sensor errors are active) 2: Injection (Normal SH control is active) 3: Dehumidify (Te Ref > 0) 4: Force OD (Manual control) 5: Defrost state (Def Activate = 1) 6: Hold1 state (Until Hold1 Time expires) 7: Hold2 state (Until Hold2 Time expires) 8: Startup (Startup time > 0) 9 -15: unused			

⁽¹⁾ Removing a pressure sensor caused no status bit change for three minutes.

4.4 Dimensions

Figure 19: EIM 336 Dimensions

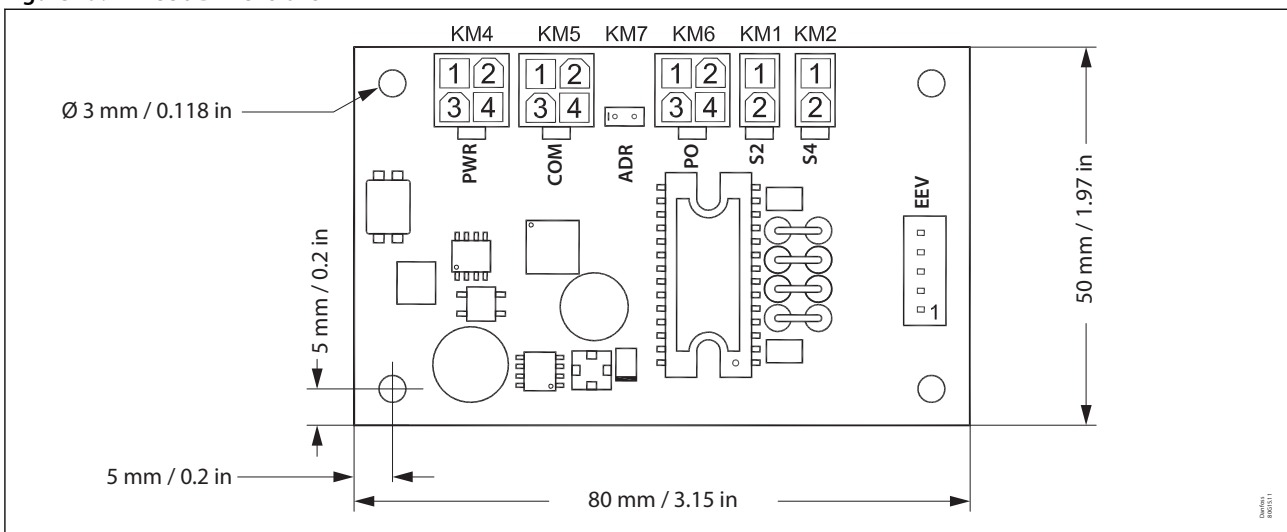
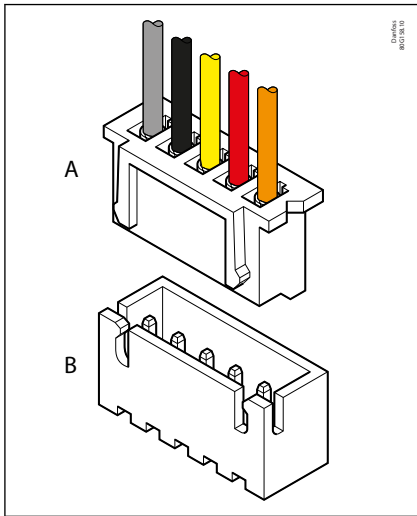

Table 24: EIM 336 connection port description

Connection port		Description
S2	KM1	1 Pt 1000
		2
S4	KM2	1 PNU no 64100 = 1: Digital input for start/stop.
		2 PNU no 64100 = 0: PT1000
Power & com.	KM4	1 Power supply (+)
		2 RS485 (+)
		3 RS485 (-)
		4 Power supply (-)
Modbus Adr.	KM7	Jumper mounted = Indoor unit (evaporator) Modbus address stored in PNU no 40041 (default = 165) Jumper not mounted = Outdoor unit (condenser) Modbus address stored in PNU no. 40042 (default 164)
Com	KM5	1 Drain (D)
		2 RS485 (TxD+/RxD+)
		3 RS485 (TxD-/RxD-)
		4 Not Used
Po	KM6	1 Common
		2 Pressure signal 10-90% of supply voltage
		3 Power supply for pressure sensor 5 V d.c.
		4 Not Used
Valve (EEV)	KM9	1 OUT B+ (Orange)
		2 OUT A- (Red)
		3 OUT B- (Yellow)
		4 OUT A+ (Black)
		5 Common (Grey - Only used for Unipolar)

Figure 20: JST XHP-5 CONNECTOR



- A** Connector on ETS 6 coil
- B** Connector on EIM 336 controller

Figure 21: 4 way MINI-FIT RECEPTACLE Molex 39-01-2040 or similar

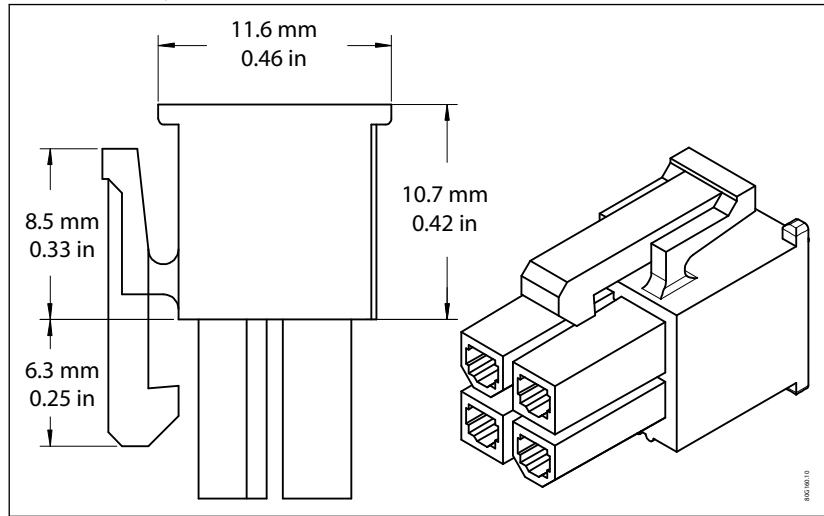

Figure 22: 2 WAY MINI-FIT RECEPTACLE Molex 39-01-2020 or similar

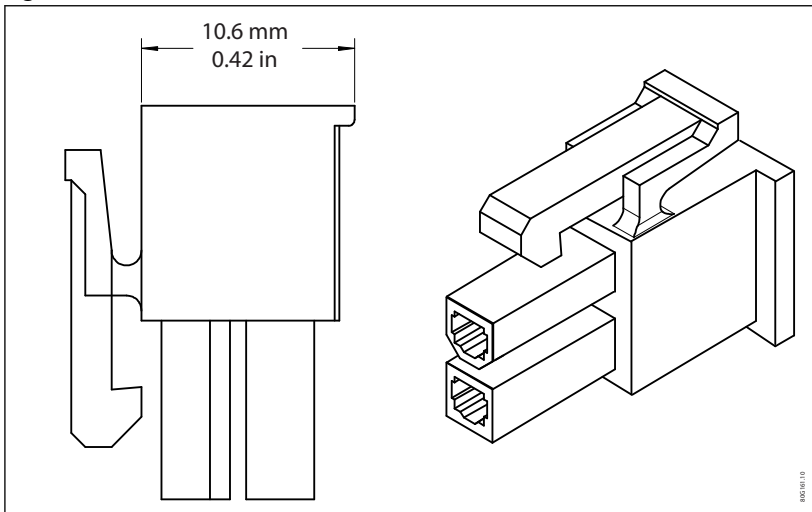
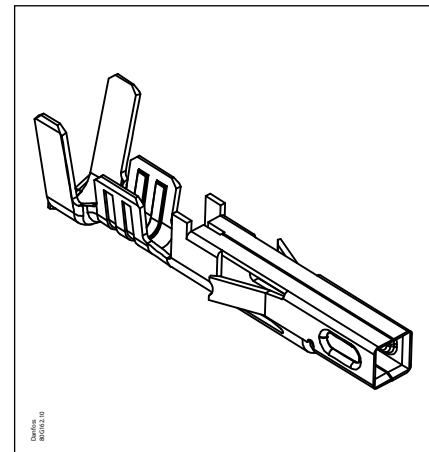

Figure 23: RECEPT CONTACT 24-18AWG Molex 39-00-0039 or similar



⚠ WARNING:

Caution must be taken against direct grounding of sensor, communication, power supply or EEV valve terminals. Failure to apply with this instruction can cause unrecoverable damaged to the controller.

5 Ordering

Table 25: Ordering

Type	Packaging	code no.
EIM 336	Single pack	080G1002

5.1 Accessories

Table 26: Accessories

Type /description	Packaging	Code no.
Connector kit for 5x EIM Controller	Single pack	080G1601
MYK - EIM interfacer ⁽¹⁾	Single pack	080G0073

⁽¹⁾ Please contact your local Danfoss supplier for required software

6 Certificates, declarations, and approvals

The list contains all certificates, declarations, and approvals for this product type. Individual code number may have some or all of these approvals, and certain local approvals may not appear on the list.

Some approvals may change over time. You can check the most current status at danfoss.com or contact your local Danfoss representative if you have any questions.

Table 27: Certificates, declarations, and approvals

Document name	Document type	Document topic	Approval authority
UA.10146.D.00071_1-19	UA Declaration	EMCD/LVD	LLC CDC EURO TYSK

7 Online support

Danfoss offers a wide range of support along with our products, including digital product information, software, mobile apps, and expert guidance. See the possibilities below.

The Danfoss Product Store



The Danfoss Product Store is your one-stop shop for everything product related—no matter where you are in the world or what area of the cooling industry you work in. Get quick access to essential information like product specs, code numbers, technical documentation, certifications, accessories, and more.

Start browsing at store.danfoss.com.

Find technical documentation



Find the technical documentation you need to get your project up and running. Get direct access to our official collection of data sheets, certificates and declarations, manuals and guides, 3D models and drawings, case stories, brochures, and much more.

Start searching now at www.danfoss.com/en/service-and-support/documentation.

Danfoss Learning



Danfoss Learning is a free online learning platform. It features courses and materials specifically designed to help engineers, installers, service technicians, and wholesalers better understand the products, applications, industry topics, and trends that will help you do your job better.

Create your Danfoss Learning account for free at www.danfoss.com/en/service-and-support/learning.

Get local information and support



Local Danfoss websites are the main sources for help and information about our company and products. Find product availability, get the latest regional news, or connect with a nearby expert—all in your own language.

Find your local Danfoss website here: www.danfoss.com/en/choose-region.