

Data sheet

Industrial Refrigeration Stainless Steel Valves

Shut-off valves SVA-S/L SS
 Hand-operated regulating valves REG-SA/SB SS
 Check & stop valves SCA-X SS
 Check Valves CHV-X SS
 Strainers FIA SS
 Pressure regulating valves OFV-SS
 Gauge valves SNV-SS
 Solenoid valves EVRS/EVRST



Danfoss Industrial Refrigeration extends a range of stainless steel valves for special application requirements.

The valve range includes for valve sizes DN 15 mm (1/2 in.) to DN 125 mm (5 in.) in angleway and straight execution and includes:

The range has been extended to meet the increased demand brought about by

1. the need for higher protection of external surfaces on valves and fittings
2. the need to meet developments in the way that plants are being designed.

In certain specific areas such as outdoor applications and corrosive atmospheres, such as coastal installations, there is a need for high surface protection to prevent failure due to corrosion.

Today's food safety standards often call for daily treatment with detergents to protect against bacteria growth, again producing a need for high surface protection.

Features

• Optional accessories:

	Vented cap	Handwheel
SVA-S/L SS	X	X
REG-SA/SB SS	X	
SCA-X SS	X	
CHV-X SS		
FIA SS		
OFV-SS	X	

• Designed to give favourable flow conditions.
 • Internal backseating enables replacement of the spindle seal whilst the valve is active, i.e. under pressure (SVA-S/L SS, REG-SA/SB SS, SCA-X SS, OFV-SS).

- Housing is made of special cold resistant stainless steel approved for low temperature operations.
- Easy to disassemble for inspection and service.
- SVA-S/L SS Shut-off valves can accept flow in either direction.
- Compact and light valves for easy handling and installation.
- Classification: DNV, CRN, BV, EAC etc. To get an updated list of certification on the products please contact your local Danfoss Sales Company.

Contents	Page
Shut-off valves SVA-S/L SS:	
Features SVA-S/L SS	3
Pressure and temperature range	3
Technical data	3
Design	4
Connections	4
Material specification	5
Dimensions and weights	9
Ordering	12
Hand-operated regulating valves REG-SA SS and REG-SB SS:	
Features REG-SA SS and REG-SB SS	14
Pressure and temperature range	14
Technical data	14
Design	15
Connections	15
Computation and selection	16
Material specification	22
Dimensions and weights	23
Ordering	24
Check & stop valves and check valves SCA-X SS and CHV-X SS:	
Features SCA-X SS and CHV-X SS	26
Pressure and temperature range	26
Technical data	26
Design	27
Connections	27
Material specification	28
Dimensions and weights	29
Ordering complete valves	30
Strainers FIA SS:	
Features FIA SS	31
Pressure and temperature range	31
Technical data	31
Design	32
Connections	32
Selection of strainer size	33
Material specification	34
Dimensions and weights	35
Ordering	36
Pressure regulating valves OFV-SS:	
Features OFV-SS	37
Technical data	37
Design	38
Connections	38
Material specification	39
Dimensions and weights	40
Ordering	41
Gauge valve SNV-SS:	
Features SNV-SS	42
Technical data	42
Design	42
Connections	42
Material specification	43
Dimensions and weights	44
Ordering	44
Solenoid valves EVRS and EVRST:	
Features EVRS and EVRST	45
Technical data	45
Design / Function	47
Material specification	48
Dimensions and weights	49
Ordering	50

**Shut-off valves
SVA-S/L SS**

In certain specific areas such as outdoor applications and corrosive atmospheres, such as coastal installations, there is a need for high surface protection to prevent failure due to corrosion.

Today's food safety standards often call for daily treatment with detergents to protect against bacteria growth, again producing a need for high surface protection.

SVA-S/L SS are angleway and straightway stainless steel shut-off valves, which are designed to meet all industrial refrigeration application requirements.

The valves are designed to give favourable flow characteristics and are easy to dismantle and repair when necessary. The valve cone is designed to ensure perfect closing.



**Features
SVA-S/L SS**

- Applicable to HCFC, HFC, R717 (Ammonia), R744 (CO₂) and all flammable refrigerants.
- Optional accessories:
 - Heavy duty industrial hand wheel for frequent operation.
 - Cap for infrequent operation.
- Available in angleway and straightway versions with Standard neck or Long neck (DN 15 to DN 40) for insulated systems.
- Designed to give favourable flow conditions.
- Internal backseating enables replacement of the spindle seal whilst the valve is active, i.e. under pressure.
- Housing is made of stainless steel approved for low temperature operations.
- Easy to disassemble for inspection and service.
- SVA-S/L SS shut-off valves can accept flow in either direction.
- Butt-weld DIN and ANSI connections.
- Maximum allowable working pressure and temperature range:

DN 15 – 65	52 bar / 754 psi at -60 – 50 °C / -76 – 122 °F
DN 80 – 125	50 bar / 725 psi at -60 – 50 °C / -76 – 122 °F
- For SVA-S/L SS see the relation between PS and temperature in the below curve.
- Temperature range: -60 – 150 °C / 76 – 302°F.
- Compact and light valves for easy handling and installation.
- Classification: DNV, CRN, BV, EAC etc. To get an updated list of certification on the products please contact your local Danfoss Sales Company.

Pressure and temperature range

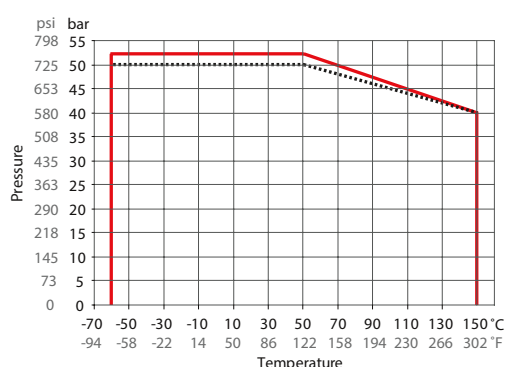

Technical data

- **Refrigerants**
Applicable to HCFC, HFC, R717 (Ammonia), R744 (CO₂) and all flammable refrigerants. For further information please contact your local Danfoss Sales Company.
- **Temperature Range**
-60 – 150 °C / -76 – 302 °F.
- **Pressure range**
The valves are designed for max. working pressure 52 bar g / 754 psi g.

Design
Connections

Available with the following connections:

- Butt-weld DIN (EN 10220)
DN 15 – 125 (½ – 5 in.)
- Butt-weld ANSI (B 36.19M)
DN 15 – 100 (½ – 4 in.)

Housing

Made of stainless steel approved for low temperature operations.

Valve cone

The valve cone can be turned on the spindle, thus there will be no friction between the cone and the seat, when the valve is opened and closed. A teflon tightening ring provides perfect sealing at a minimum closing momentum.

Spindle

Made of polished stainless steel, ideal for O-ring sealing. Furthermore, parts of the spindle are heat treated to obtain anti-abrasive/adhesive properties.

Packing gland

The stainless steel packing gland comprises a spring loaded seal packing gland which ensures a perfect tightness in the range: -60 – 150 °C / -76 – 302 °F.

The packing glands are equipped with a scraper ring to prevent penetration of dirt and ice into the packing gland.

Pressure Equipment Directive (PED)

The stainless steel valves are approved and CE marked in accordance with the Pressure Equipment Directive - 97/23/EC.

Installation

It is recommended that the valves be installed in the direction of flow indicated by the arrow on the valve body. The valve can be installed in the opposite direction but this slightly reduces the k_v -value (C_v -value).

The valve is designed to withstand high internal pressure. However, the piping system in general should be designed to avoid liquid traps and reduce the risk of hydraulic pressure caused by thermal expansion.

For further information refer to installation instructions for SVA-S/L SS.

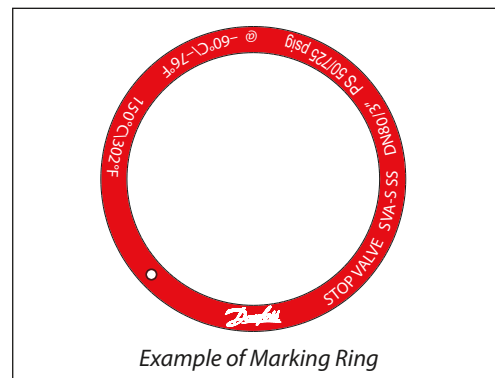

SVA-S/L SS			
Nominal bore	DN ≤ 25 mm (1 in.)	DN32-80 mm (1 ¼ – 3 in.)	DN100 – 125 mm (4 – 5 in.)
Classified for	Fluid group I		
Category	Article 3, paragraph 3	II	III

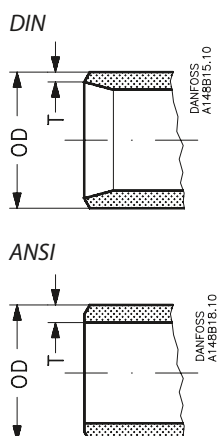
Connections

Size	OD	T
Butt-weld DIN (EN 10220)		
15	mm	21.3
½	in.	0.839
20	mm	26.9
¾	in.	1.059
25	mm	33.7
1	in.	1.327
32	mm	42.4
1 ¼	in.	1.669
40	mm	48.3
1 ½	in.	1.902
50	mm	60.3
2	in.	2.37
65	mm	76.1
2 ½	in.	3
80	mm	88.9
3	in.	3.50
100	mm	114.3
4	in.	4.50
125	mm	139.7
5	in.	5.50

Size	OD	T
Butt-weld ANSI B 36.19M, SCHEDULE 40		
15	mm	21.3
½	in.	0.839
20	mm	26.9
¾	in.	1.06
25	mm	33.7
1	in.	1.33
32	mm	42.4
1 ¼	in.	1.67
40	mm	48.3
1 ½	in.	1.9
Butt-weld ANSI B 36.19M, SCHEDULE 10		
50	mm	60.3
2	in.	2.37
65	mm	73
2 ½	in.	2.87
80	mm	88.9
3	in.	3.5
100	mm	114.3
4	in.	4.5

Material specification

SVA-SS 15 – 40 (½ – 1 ½ in.)

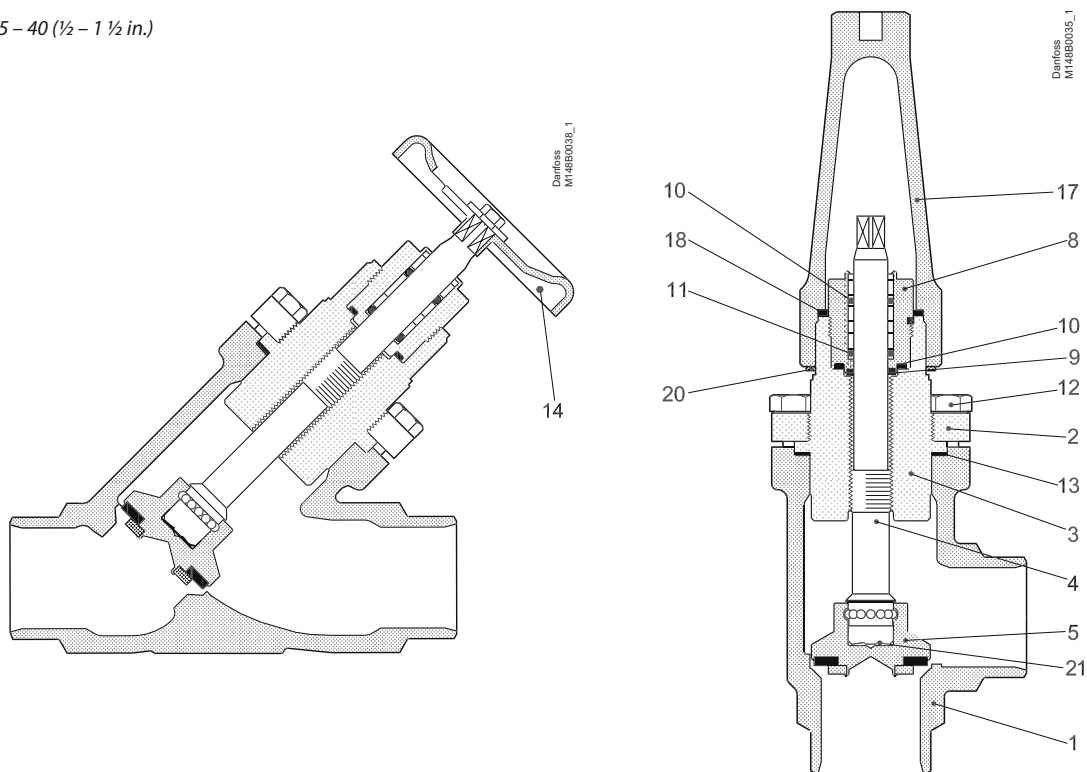

No.	Part	Material	EN	ISO	ASTM
1	Housing	Stainless steel	GX5CrNi19-10 EN10213-4		AISI 304
2	Bonnet, Flange	Stainless steel	X5CrNi18-10 EN10088		AISI 304
3	Bonnet, Insert	Stainless steel	X8CrNiS18-9 DIN 17440		AISI 303
4	Spindle	Stainless steel	X8CrNiS18-9 DIN 17440	Type 17, 683/13	AISI 303
5	Cone	Steel			
8	Packing gland	Stainless steel	X8CrNiS18-9 10088	Type 17 683/13	AISI 303
9	Packing washer	Aluminium			
10	O-ring	Cloroprene (Neoprene)			
11	Spring loaded Teflon ring	PTFE			
12	Bolts	Stainless steel	A2-70	A2-70	Type 308
13	Gasket	Fiber, Non-asbestos			
14	Handwheel	Steel			
17	Cap	Aluminium			
18	Gasket for cap	Nylon			
20	Identification ring	Stainless steel			
21	Disk spring	Steel			

Material specification

SVA-L SS 15 – 40 (½ – 1 ½ in.)

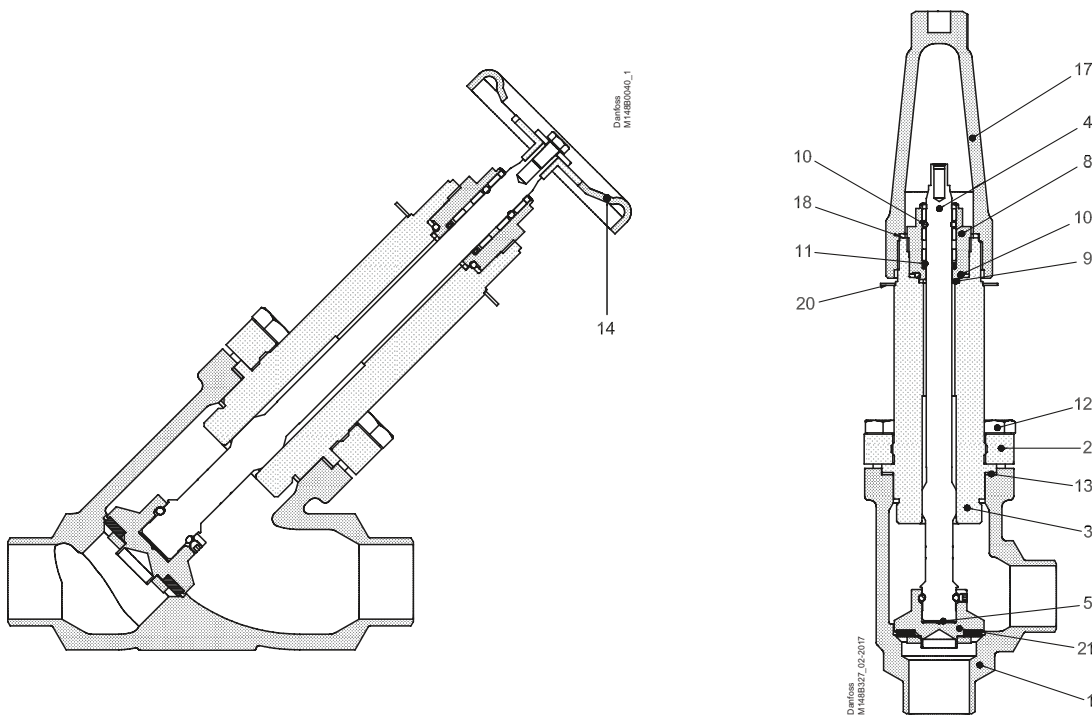

No.	Part	Material	EN	ISO	ASTM
1	Housing	Stainless steel	GX5CrNi19-10 EN10213-4		AISI 304
2	Bonnet, Flange	Stainless steel	X5CrNi18-10 EN10088		AISI 304
3	Bonnet, Insert	Stainless steel	X8CrNiS18-9 DIN 17440		AISI 303
4	Spindle	Stainless steel	X8CrNiS18-9 DIN 17440	Type 17, 683/13	AISI 303
5	Cone	Steel			
8	Packing gland	Stainless steel	X8CrNiS18-9 10088	Type 17 683/13	AISI 303
9	Packing washer	Aluminium			
10	O-ring	Cloroprene (Neoprene)			
11	Spring loaded Teflon ring	PTFE			
12	Bolts	Stainless steel	A2-70	A2-70	Type 308
13	Gasket	Fiber, Non-asbestos			
14	Handwheel	Steel			
17	Cap	Aluminium			
18	Gasket for cap	Nylon			
20	Identification ring	Stainless steel			
21	Disk spring	Steel			

Material specification

SVA-SS 50 – 65 (2 – 2 ½ in.)

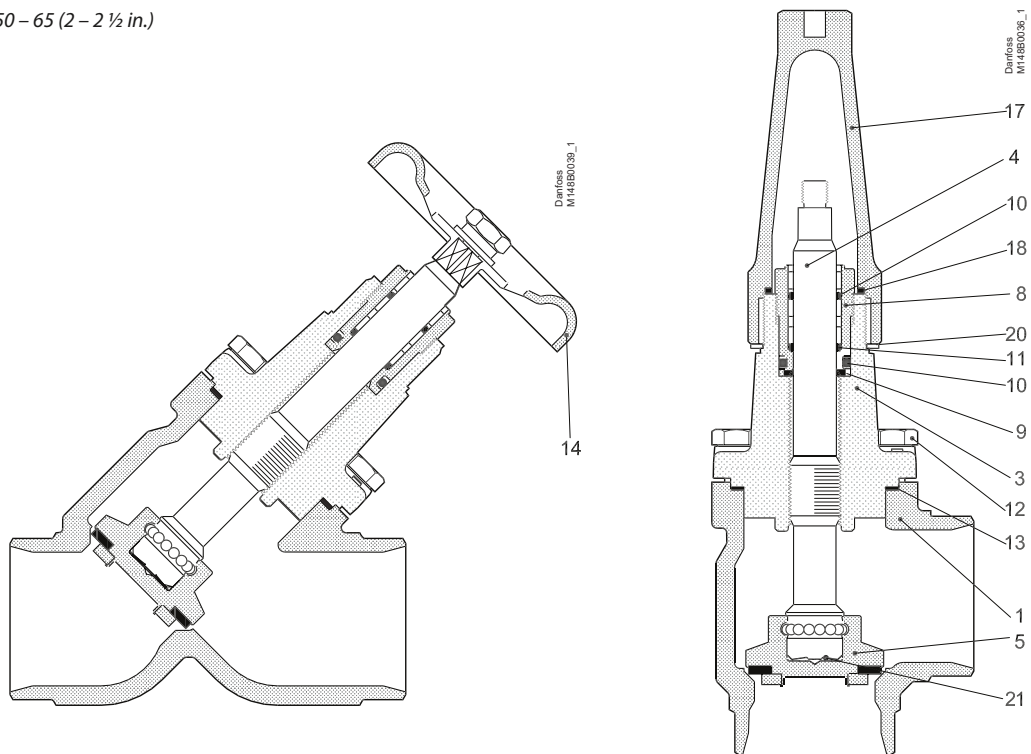

No.	Part	Material	EN	ISO	ASTM
1	Housing	Stainless steel	GX5CrNi19-10 EN10213-4		AISI 304
3	Valve bonnet	Stainless steel	GX5CrNi19-10 EN10213-4		AISI 304
4	Spindle	Stainless steel	X8CrNiS18-9 DIN 17440	Type 17, 683/13	AISI 303
5	Cone	Steel			
8	Packing gland	Stainless steel	X8CrNiS18-9 10088	Type 17 683/13	AISI 303
9	Packing washer	Aluminium			
10	O-ring	Cloroprene (Neoprene)			
11	Spring loaded Teflon ring	PTFE			
12	Bolts	Stainless steel	A2-70	A2-70	Type 308
13	Gasket	Fiber, Non-asbestos			
14	Handwheel	Steel			
17	Cap	Aluminium			
18	Gasket for cap	Nylon			
19	Locking nut	Steel			
20	Identification ring	Stainless steel			
21	Disk spring	Steel			

Material specification

SVA-S SS 80 – 125 (3 – 5 in.)

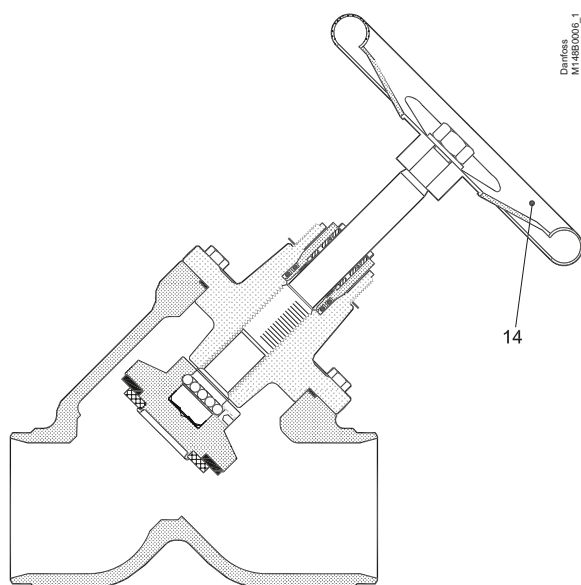

Danfoss
MFA88008_1

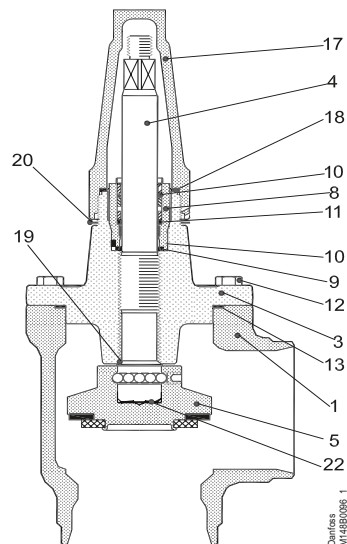

Danfoss
MFA88008_1

No.	Part	Material	EN	ISO	ASTM
1	Housing	Stainless steel	GX5CrNi19-10 EN10213-4		AISI 304
3	Valve bonnet	Stainless steel	GX5CrNiMo19-11-2 EN10213-4		AISI 304
4	Spindle	Stainless steel	X5CrNi18-10 DIN 17440	Type 17, 683/13	AISI 303
5	Cone Cone seal	Steel Teflon (PTFE)			
8	Packing gland	Stainless steel	X8CrNiS18-9 10088	Type 17 R 683/13	AISI 303
9	Packing washer	Aluminium			
10	O-ring	Cloroprene (Neoprene)			
11	Spring loaded Teflon ring	PTFE			
12	Bolts	Stainless steel	A2-70	A2-70	Type 308
13	Gasket	Fiber, Non-asbestos			
14	Hand wheel	Steel			
17	Cap	Aluminium			
18	Gasket for cap	Nylon (PA 6)			
19	Soft backseat	Teflon (PTFE)			
20	Identification ring	Stainless steel			
22	Disk spring	Steel			

Dimensions and weights

SVA S SS 15 – 40 (½ – 1 ½ in.) in angleway version with cap / hand wheel

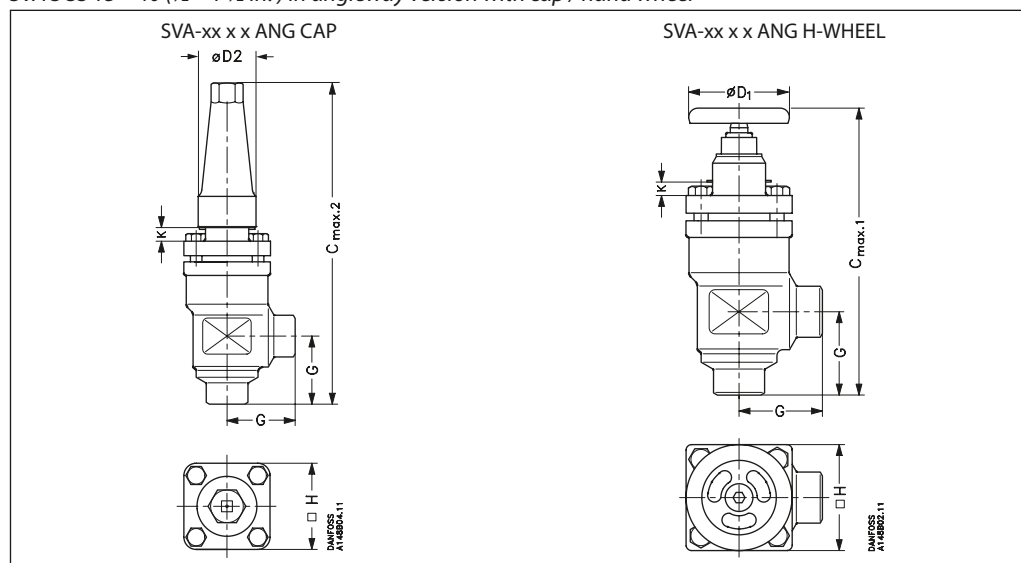

Valve size	K	C _{max.1}	C _{max.2}	G	ØD ₁	ØD ₂	□H	Weight	
SVA-S SS									
SVA-S SS 15 – 20	mm	4	178	189	45	60	38	60	1.4 kg
SVA-S SS ½ – ¾"	in.	0.16	7.00	7.44	1.77	2.36	1.5	2.36	3.1 lbs
SVA-S SS 25 – 40	mm	12	234	268	55	80	50	70	2.4 kg
SVA-S SS 1 – 1 ½"	in.	0.47	9.21	10.55	2.17	3.15	1.97	2.76	5.3 lbs

Specified weights are approximate values only.

SVA-S/L SS 15 - 40 (½ – 1 ½ in.) straightway version with cap / hand wheel

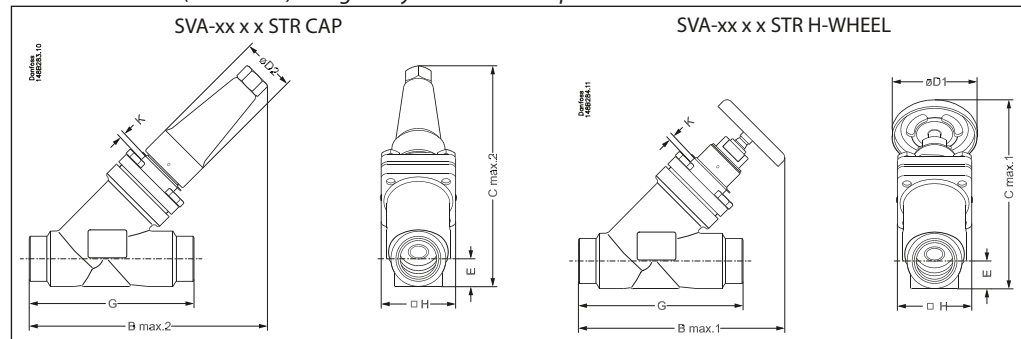

Valve size	K	C _{max.1}	C _{max.2}	B _{max.1}	B _{max.2}	E	G	ØD ₁	ØD ₂	□H	Weight	
SVA-S SS												
SVA-S SS 15 – 20	mm	4	146	141	160	156	20	120	60	38	60	2.0 kg
SVA-S SS (½ – ¾)"	in.	0.16	5.74	5.55	6.30	6.14	0.79	4.72	2.36	1.50	2.36	4.4 lb
SVA-S SS 25 – 40	mm	12	199	208	212	222	26	155	80	50	70	3.0 kg
SVA-S SS (1 – 1 ½)"	in.	0.47	7.83	8.19	8.35	8.74	1.02	6.10	3.15	1.97	2.76	6.6 lb
SVA-L SS												
SVA-L SS 15 – 20	mm	63	188	184	202	198	20	120	60	38	60	2.0 kg
SVA-L SS (½ – ¾)"	in.	2.48	7.40	7.24	7.95	7.80	0.79	4.72	2.36	1.50	2.36	4.4 lb
SVA-L SS 25 – 40	mm	74	243	252	256	265	26	155	80	50	70	3.0 kg
SVA-L SS (1 – 1 ½)"	in.	2.91	9.57	9.92	10.08	10.43	1.02	6.10	3.15	1.97	2.76	6.6 lb

Specified weights are approximate values only.

Dimensions and weights

SVA-S SS 50 - 65 (2 - 2 ½ in.) in angleway version with cap / hand wheel

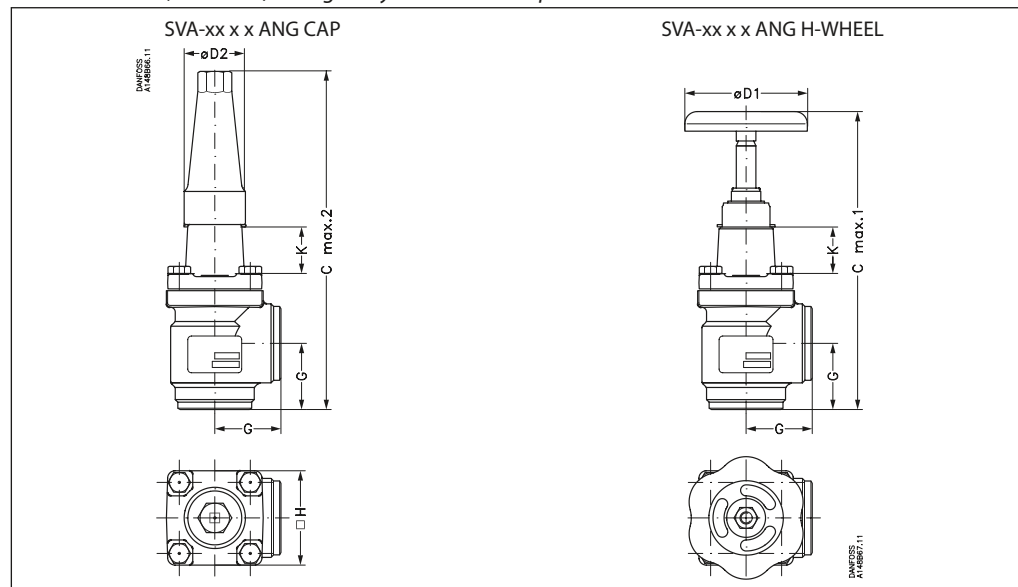

Valve size	K	C _{max.1}	C _{max.2}	G	ØD ₁	ØD ₂	ØH	Weight
------------	---	--------------------	--------------------	---	-----------------	-----------------	----	--------

SVA-S SS										
SVA-S SS 50	mm	70	284	315	60	100	50	77		3.2 kg
SVA-S SS (2)	in.	2.76	11.18	12.40	2.36	3.94	1.97	3.03		7.1 lb
SVA-S SS 65	mm	70	310	335	70	100	50	90		4.8 kg
SVA-S SS (2 ½)	in.	2.76	12.20	13.19	2.76	3.94	1.97	3.54		10.6 lb

Specified weights are approximate values only.

SVA-S SS 50 - 65 (2 - 2 ½ in.) in straightway version with cap / hand wheel

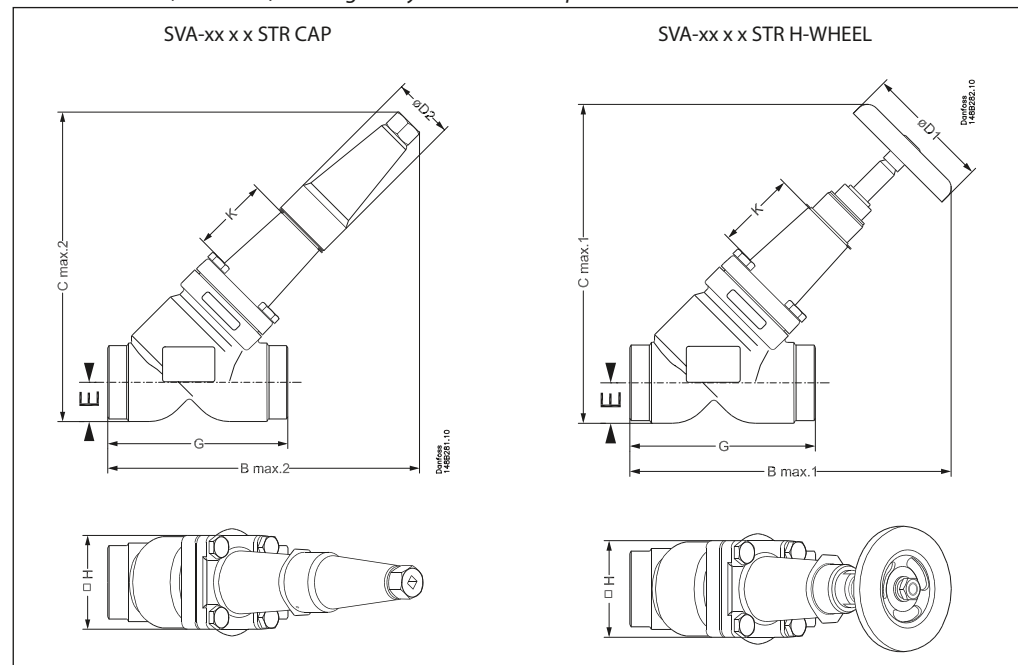

Valve size	K	B _{max.1}	B _{max.2}	C _{max.1}	C _{max.2}	E	G	ØD ₁	ØD ₂	ØH	Weight
------------	---	--------------------	--------------------	--------------------	--------------------	---	---	-----------------	-----------------	----	--------

SVA-S SS												
SVA-S SS 50	mm	70	259	259	257	257	32	148	100	50	77	4.2 kg
SVA-S SS (2)	in.	2.76	10.20	10.20	10.12	10.12	1.26	5.83	3.94	1.97	3.03	9.3 lb
SVA-S SS 65	mm	70	284	280	284	280	40	176	100	50	90	6.3 kg
SVA-S SS (2 ½)	in.	2.76	11.18	11.02	11.18	11.02	1.57	6.93	3.94	1.97	3.54	13.9 lb

Specified weights are approximate values only.

Dimensions and weights

SVA-S SS 80 – 125 (3 – 5 in.) angleway version with cap / hand wheel

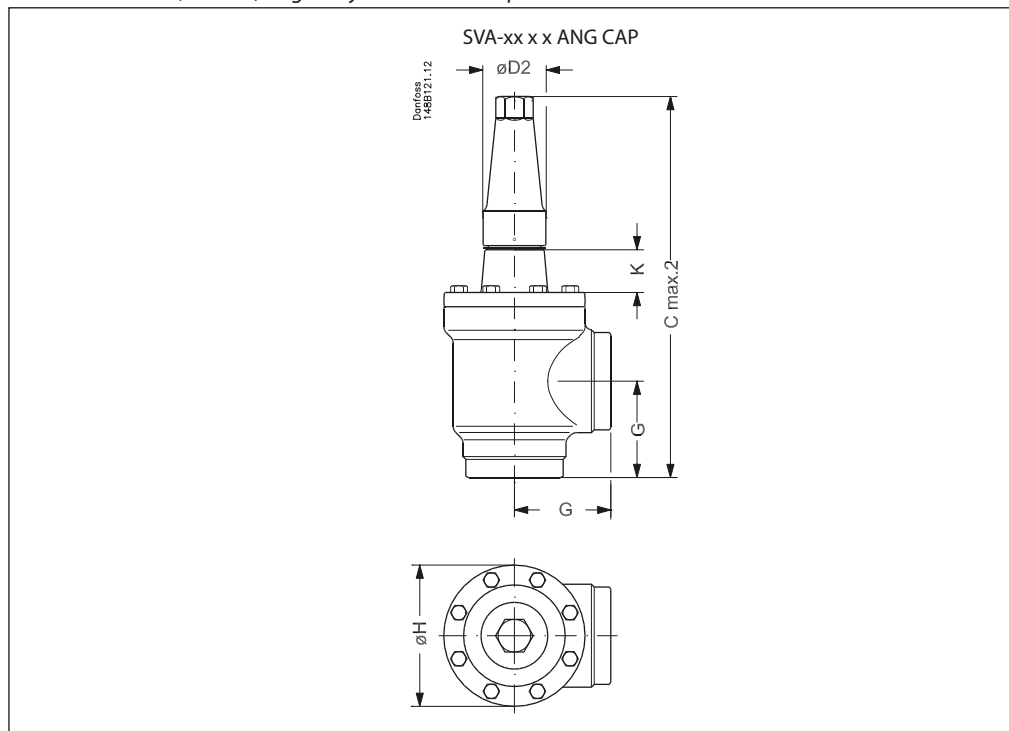

Valve size		K	$C_{\text{max.2}}$	G	øD_1	øD_2	øH	Weight
SVA-S SS								
SVA-S SS 80	mm	76	388	90	200	58	129	9.7 kg
SVA-S SS (3)	in.	3.00	15.28	3.54	7.87	2.28	5.08	21.4 lb
SVA-S SS 100	mm	90	437	106	250	58	156	15.3 kg
SVA-S SS (4)	in.	3.54	17.20	4.17	9.84	2.28	6.14	33.7 lb
SVA-S SS 125	mm	90	533	128	315	74	193	28.1 kg
SVA-S SS (5)	in.	3.54	20.98	5.04	12.40	2.91	7.60	61.9 lb

Specified weights are approximate values only.

Ordering

Please note that the type codes only serve to identify the valves, some of which may not form part of the standard product range. For further information please contact your local Danfoss Sales Company.

Type codes

Valve type	SVA-S/L SS	Shut-off valve	Available connections	
Nominal size in mm			D	A
(valve size measured on the connection diameter)	15	DN 15 (½)	x	x
	20	DN 20 (¾)	x	x
	25	DN 25 (1)	x	x
	32	DN 32 (1 ¼)	x	x
	40	DN 40 (1 ½)	x	x
	50	DN 50 (2)	x	x
	65	DN 65 (2 ½)	x	x
	80	DN 80 (3)	x	x
	100	DN 100 (4)	x	x
	125	DN 125 (5)	x	
Connections	D A	Butt-weld connection: DIN EN 10220 Butt-weld connection: ANSI B 36.19M		
Valve housing	ANG STR	Angle flow Straight flow		
Other equipment	H-WHEEL CAP	Hand wheel Cap		

Important!

Where products need to be certified according to specific certification societies or where higher pressures are required, the relevant information should be included at the time of order.

Ordering SVA-S/L SS

Example:
SVA-S SS 20 DIN angleway with hand wheel = **148B5377**

Important!

Where products need to be certified according to specific certification societies or where higher pressures are required, the relevant information should be included at the time of order.

SVA-S SS Angleway

Size		Type	MWP		Code number
mm	in.		bar	psi	
Butt-weld DIN (EN 10220)					
15	½	SVA-S SS 15 D ANG H-WHEEL	52	754	148B5289
15	½	SVA-S SS 15 D ANG CAP	52	754	148B5290
20	¾	SVA-S SS 20 D ANG H-WHEEL	52	754	148B5377
20	¾	SVA-S SS 20 D ANG CAP	52	754	148B5378
25	1	SVA-S SS 25 D ANG H-WHEEL	52	754	148B5486
25	1	SVA-S SS 25 D ANG CAP	52	754	148B5487
32	1 ¼	SVA-S SS 32 D ANG H-WHEEL	52	754	148B5566
32	1 ¼	SVA-S SS 32 D ANG CAP	52	754	148B5567
40	1 ½	SVA-S SS 40 D ANG H-WHEEL	52	754	148B5646
40	1 ½	SVA-S SS 40 D ANG CAP	52	754	148B5647
50	2	SVA-S SS 50 D ANG H-WHEEL	52	754	148B5753
50	2	SVA-S SS 50 D ANG CAP	52	754	148B5754
65	2 ½	SVA-S SS 65 D ANG H-WHEEL	52	754	148B5847
65	2 ½	SVA-S SS 65 D ANG CAP	52	754	148B5848
80	3	SVA-S SS 80 D ANG CAP	50	725	148B5928
100	4	SVA-S SS 100 D ANG CAP	50	725	148B6032
125	5	SVA-S SS 125 D ANG CAP	50	725	148B6126

Size		Type	MWP		Code number
mm	in.		bar	psi	
Butt-weld ANSI (B 36.19M SCHEDULE 40)					
15	½	SVA-S SS 15 A40 ANG CAP	52	754	148B5396
20	¾	SVA-S SS 20 A40 ANG CAP	52	754	148B5395
25	1	SVA-S SS 25 A40 ANG CAP	52	754	148B6477
32	1 ¼	SVA-S SS 32 A40 ANG CAP	52	754	148B5595
40	1 ½	SVA-S SS 40 A40 ANG CAP	52	754	148B5683

Size		Type	MWP		Code number
mm	in.		bar	psi	
Butt-weld ANSI (B 36.19M SCHEDULE 10)					
50	2	SVA-S SS 50 D/A10 ANG CAP	52	754	148B5754
65	2 ½	SVA-S SS 65 A10 ANG CAP	52	754	148B6448
80	3	SVA-S SS 80 D/A10 ANG CAP	52	754	148B5928
100	4	SVA-S SS 100 A10 ANG CAP	52	754	148B6035

ANG = Angleway
STR = Straightway

CAP = Cap
H-WHEEL = Hand wheel

SVA-S SS Straightway

Size		Type	MWP		Code number
mm	in.		bar	psi	
Butt-weld DIN (EN 10220)					
15	½	SVA-S SS 15 D STR H-WHEEL	52	754	148B5291
15	½	SVA-S SS 15 D STR CAP	52	754	148B5292
20	¾	SVA-S SS 20 D STR H-WHEEL	52	754	148B5379
20	¾	SVA-S SS 20 D STR CAP	52	754	148B5380
25	1	SVA-S SS 25 D STR H-WHEEL	52	754	148B5488
25	1	SVA-S SS 25 D STR CAP	52	754	148B5489
32	1 ¼	SVA-S SS 32 D STR H-WHEEL	52	754	148B5568
32	1 ¼	SVA-S SS 32 D STR CAP	52	754	148B5569
40	1 ½	SVA-S SS 40 D STR H-WHEEL	52	754	148B5648
40	1 ½	SVA-S SS 40 D STR CAP	52	754	148B5649
50	2	SVA-S SS 50 D STR H-WHEEL	52	754	148B5755
50	2	SVA-S SS 50 D STR CAP	52	754	148B5756
65	2 ½	SVA-S SS 65 D STR H-WHEEL	52	754	148B5849
65	2 ½	SVA-S SS 65 D STR CAP	52	754	148B5850

Size		Type	MWP		Code number
mm	in.		bar	psi	
Butt-weld ANSI (B 36.19M SCHEDULE 40)					
15	½	SVA-S SS 15 A40 STR CAP	52	754	148B5397
20	¾	SVA-S SS 20 A40 STR CAP	52	754	148B5398
25	1	SVA-S SS 25 A40 STR CAP	52	754	148B5399
32	1 ¼	SVA-S SS 32 A40 STR CAP	52	754	148B5596
40	1 ½	SVA-S SS 40 A40 STR CAP	52	754	148B5684

Size		Type	MWP		Code number
mm	in.		bar	psi	
Butt-weld ANSI (B 36.19M SCHEDULE 10)					
50	2	SVA-S SS 50 D/A10 STR CAP	52	754	148B5756
65	2 ½	SVA-S SS 65 A10 STR CAP	52	754	148B6449

Data sheet | Stainless Steel Valves 15 (½ in.) - 125 (5 in.)

Ordering

SVA-L SS Angleyway

Size		Type	MWP		Code number
mm	in.		bar	psi	

Butt-weld DIN (EN 10220)

15	½	SVA-L SS 15 D ANG H-WHEEL	52	754	148B6546
15	½	SVA-L SS 15 D ANG CAP	52	754	148B6547
20	¾	SVA-L SS 20 D ANG H-WHEEL	52	754	148B6550
20	¾	SVA-L SS 20 D ANG CAP	52	754	148B6551
25	1	SVA-L SS 25 D ANG H-WHEEL	52	754	148B6554
25	1	SVA-L SS 25 D ANG CAP	52	754	148B6555
32	1 ¼	SVA-L SS 32 D ANG H-WHEEL	52	754	148B6558
32	1 ¼	SVA-L SS 32 D ANG CAP	52	754	148B6559
40	1 ½	SVA-L SS 40 D ANG H-WHEEL	52	754	148B6562
40	1 ½	SVA-L SS 40 D ANG CAP	52	754	148B6563

ANG = Angleyway
 STR = Straightway
 CAP = Cap
 H-WHEEL = Hand wheel

SVA-L SS Straightway

Size		Type	MWP		Code number
mm	in.		bar	psi	

Butt-weld DIN (EN 10220)

15	½	SVA-L SS 15 D STR H-WHEEL	52	754	148B6548
15	½	SVA-L SS 15 D STR CAP	52	754	148B6549
20	¾	SVA-L SS 20 D STR H-WHEEL	52	754	148B6552
20	¾	SVA-L SS 20 D STR CAP	52	754	148B6553
25	1	SVA-L SS 25 D STR H-WHEEL	52	754	148B6556
25	1	SVA-L SS 25 D STR CAP	52	754	148B6557
32	1 ¼	SVA-L SS 32 D STR H-WHEEL	52	754	148B6560
32	1 ¼	SVA-L SS 32 D STR CAP	52	754	148B6561
40	1 ½	SVA-L SS 40 D STR H-WHEEL	52	754	148B6564
40	1 ½	SVA-L SS 40 D STR CAP	52	754	148B6565

**Hand-operated regulating valves
REG-SA SS and REG-SB SS**

In certain specific areas such as outdoor applications and corrosive atmospheres, such as coastal installations, there is a need for high surface protection to prevent failure due to corrosion.

Today's food safety standards often call for daily treatment with detergents to protect against bacteria growth, again producing a need for high surface protection.

REG-SA SS and REG-SB SS are angle-way and straight-way hand-operated regulating valves, which act as normal stop valves in closed position.

The valves are designed to meet the strict quality requirements on refrigerating installations specified by the international classification societies and are carefully designed to present favourable flow conditions and accurate linear characteristics.

The valves are equipped with vented cap and have internal backseating enabling the spindle seal to be replaced with the valve still under pressure.



**Features
REG-SA SS and REG-SB SS**

- Applicable to HCFC, HFC, R717 (Ammonia), R744 (CO₂), Propane, Butane, Iso-Butane and Ethane.
- Designed to give favourable flow conditions.
- Internal backseating enables replacement of the spindle seal whilst the valve is active, i.e. under pressure
- Housing is made of special cold resistant stainless steel approved for low temperature operations.
- Easy to disassemble for inspection and service.
- Butt-weld DIN and ANSI connections.
- Max. operating pressure: 52 bar g / 754 psig
- Temperature range: -60 – 150 °C / -76 – 302 °F.
- Compact and light valves for easy handling and installation.
- Classification: DNV, CRN, BV, EAC etc. To get an updated list of certification on the products please contact your local Danfoss Sales Company.

Pressure and temperature range

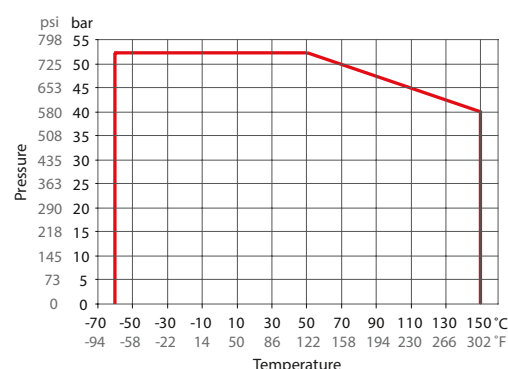

REG-SA SS/REG-SB SS DN15-DN40

Technical data

- **Refrigerants**
Applicable to HCFC, HFC, R717 (Ammonia), R744 (CO₂), Propane, Butane, Iso-Butane and Ethane.
For further information please contact your local Danfoss Sales Company.
- **Temperature range**
-60 – 150 °C / -76 – 302 °F
- **Max working pressure**
52 bar g / 754 psi g
- **Flow coefficients**
Flow coefficients for fully opened valves from $k_v = 0.15$ to $80 \text{ m}^3/\text{h}$ ($C_v = 0.17$ to $92.5 \text{ USgal}/\text{min}$).

Design
Housing

Made of stainless steel approved for low temperature operations.

Connections

Available with the following connections:

- Butt-weld DIN (EN 10220)
DN 15 - 40 (½ – 1 ½ in.)
- Butt-weld ANSI (B 36.19M)
DN 15 - 40 (½ – 1 ½ in.)

The cone

The valves are available in two different versions – REG-SA SS with an A cone and REG-SB SS with a B cone. The A cone is designed for expansion lines, while the B cone is designed for regulating purposes e.g. liquid lines.

The valve cone is designed to ensure perfect regulation and provide an extensive regulating area. Irrespective of the refrigerant used, it is easy to obtain the correct capacity. A cone seal ring provides perfect sealing at a minimum closing momentum.

The valve cone can be turned on the spindle, thus there will be no friction between the cone and the seat when the valve is opened and closed.

Spindle

Made of polished stainless steel, ideal for O-ring sealing. Furthermore, parts of the spindle are heat treated to obtain anti-abrasive/adhesive properties.

Packing gland - REG-SA SS and REG-SB SS

The stainless steel packing gland comprises a spring loaded seal packing gland which

ensures a perfect tightness in the range: -60 – 150 °C / -76 – 302 °F.

The packing glands are equipped with a scraper ring to prevent penetration of dirt and ice into the packing gland.

Installation

Install the valve with the spindle up or in horizontal position. The flow must be directed towards the cone.

The valve is designed to withstand high internal pressure. However, the piping system in general should be designed to avoid liquid traps and reduce the risk of hydraulic pressure caused by thermal expansion.

For further information refer to product instruction for REG-SA SS and REG-SB SS.

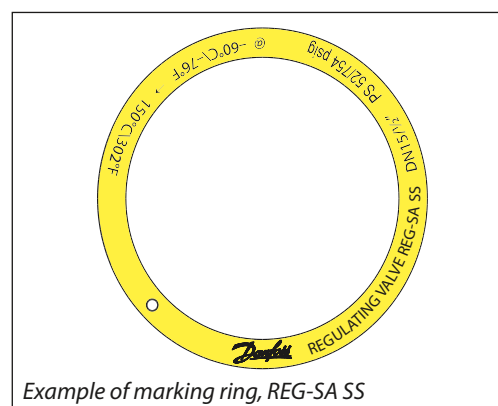
Pressure Equipment Directive (PED)

REG-SA/SB SS valves are approved according to the European standard specified in the Pressure Equipment Directive and are CE marked.

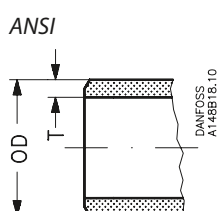
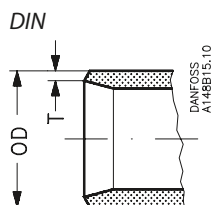

REG-SA SS and REG-SB SS valves		
Nominal bore	DN = < 25 mm (1 in.)	DN32-40 mm (1 ¼ – 1 ½ in.)
Classified for	Fluid group I	
Category	Article 3, paragraph 3	II

Connections

Size	OD	T
Butt-weld DIN (EN 10220)		
15	mm	21.3
½	in.	0.839
20	mm	26.9
¾	in.	1.059
25	mm	33.7
1	in.	1.327
32	mm	42.4
1 ¼	in.	1.669
40	mm	48.3
1 ½	in.	1.902

Size	OD	T
Butt-weld ANSI B 36.19M, SCHEDULE 40		
15	mm	21.3
½	in.	0.839
20	mm	26.9
¾	in.	1.06
25	mm	33.7
1	in.	1.33
32	mm	42.4
1 ¼	in.	1.67
40	mm	48.3
1 ½	in.	1.9

Computation and selection

Introduction

In refrigeration plants, regulating valves are primarily used in liquid lines in order to regulate the flow of refrigerant. The valves can, however, also be used as expansion valves. From a calculation point of view the two fields of application are very different.

Normal flow is the term used to describe the general case where the flow through the valve is proportional to the square root of the pressure drop across it and inversely proportional to the density of the refrigerant (Bernoullis equation).

This relationship between mass flow, pressure drop and density satisfies the majority of all valve applications with refrigerants and brines.

Normal flow is characterised by turbulent flow through the valve without any phase change. The following capacity curves are based on the above mentioned assumption.

Application of the regulating valves outside the normal flow area will reduce the capacity of the valve considerably. In such cases it is recommended to use "DIRcalc™" (Danfoss Industrial Refrigeration calculation programme).

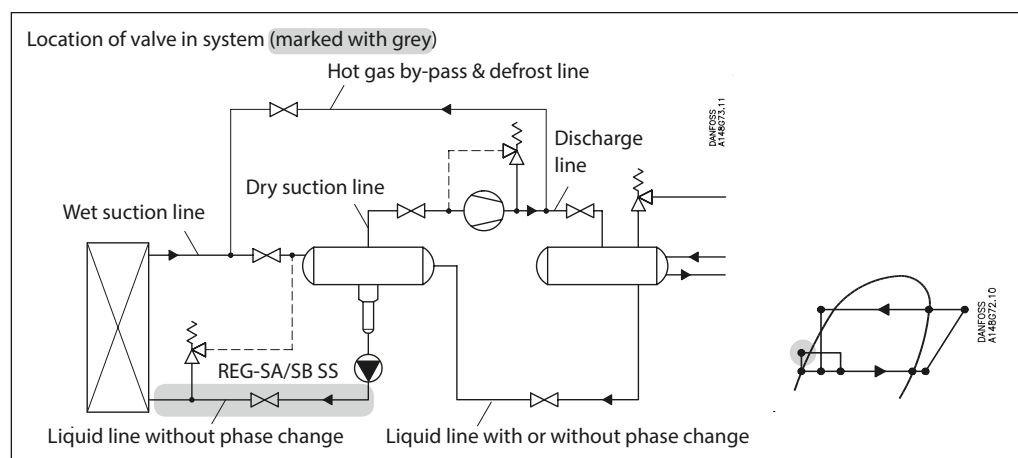

Sizing regulating valve for liquid flow
 Liquid refrigerants: Use the liquid tables, fig. 6 - 10. For other refrigerants and brines, "Normal flow" (Turbulent flow); see below and use the flow coefficient tables (fig. 1 - 2).

SI-units

Mass flow:

$$k_v = \frac{G}{\sqrt{\rho \times 1000 \times \Delta p}} = G \times C_A \text{ [m}^3/\text{h]}$$

Volume flow:

$$k_v = \frac{\dot{V}}{\sqrt{\frac{1000 \times \Delta p}{\rho}}} \text{ [m}^3/\text{h]}$$

Imperial units

Mass flow:

$$C_v = \frac{0.95 \times G}{\sqrt{\rho \times \Delta p}} = 31.6 \times G \times C_A \text{ [USgal/min.]}$$

Volume flow:

$$C_v = \frac{0.127 \times \dot{V}}{\sqrt{\frac{\Delta p}{\rho}}} \text{ [USgal/min.]}$$

k_v	[m ³ /h]	Quantity [m ³ /h] of water flowing through a valve at a pressure loss of 1 bar (according to VDE/VDI Norm 2173).	C_v	[US gal/min]	Quantity [US gal/min] of water flowing through a valve at a pressure loss of 1 psi.
P_1	[bar]	Pressure before the valve (upstream).	P_1	[psi]	Pressure before the valve (upstream).
P_2	[bar]	Pressure after the valve (downstream).	P_2	[psi]	Pressure after the valve (downstream).
Δp	[bar]	Actual pressure loss across the valve ($P_1 - P_2$).	Δp	[psi]	Actual pressure loss across the valve ($P_1 - P_2$).
G	[kg/h]	Mass flow through the valve.	G	[lb/min]	Mass flow through the valve.
\dot{V}	[m ³ /h]	Volume flow through the valve.	\dot{V}	[US gal/min]	Volume flow through the valve.
ρ	[kg/m ³]	Density of the refrigerant before the valve.	ρ	[lb/ft ³]	Density of the refrigerant before the valve.
C_A		Calculation factor (fig. 5).	C_A		Calculation factor (fig. 5).

Computation and selection

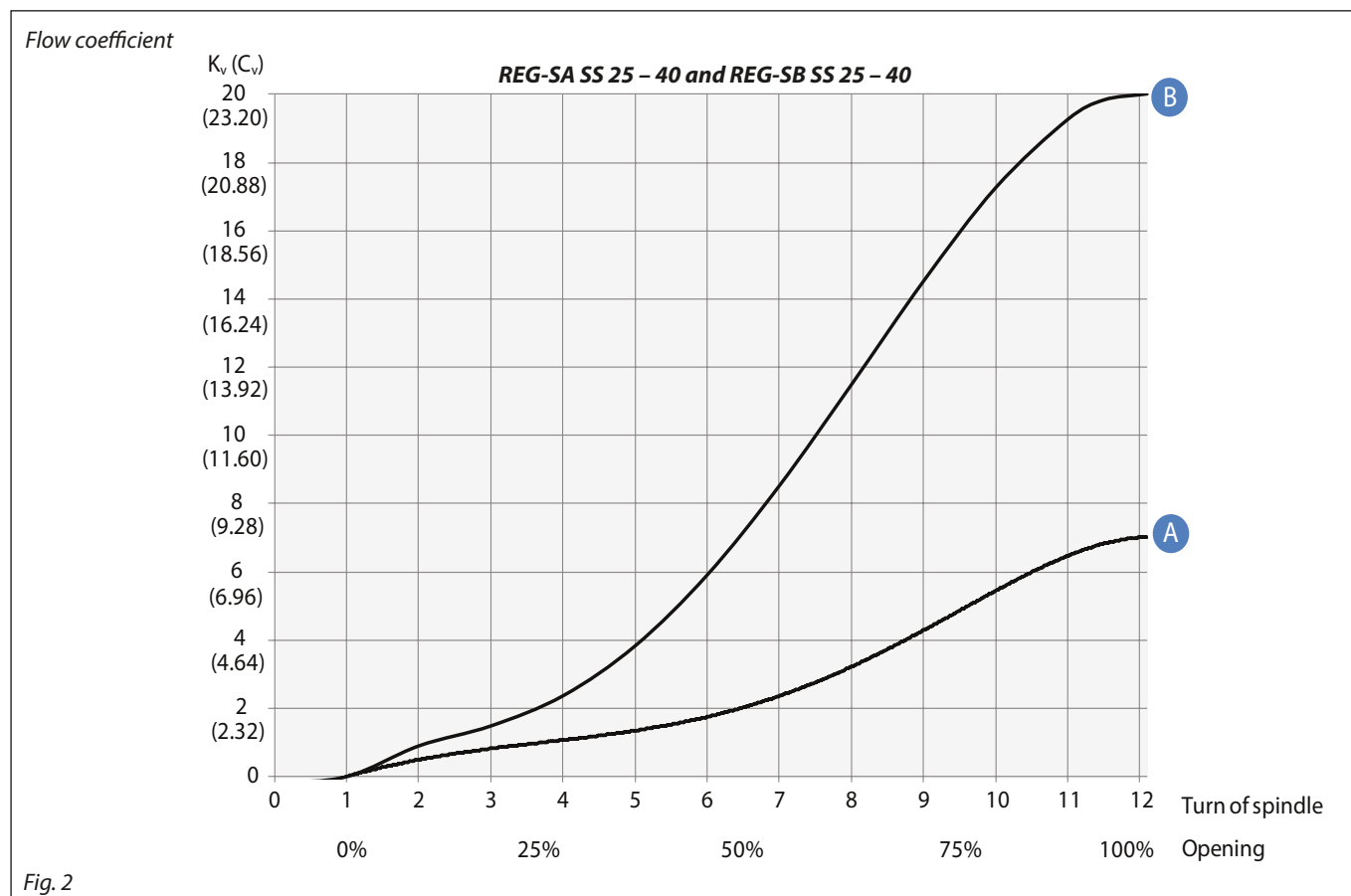
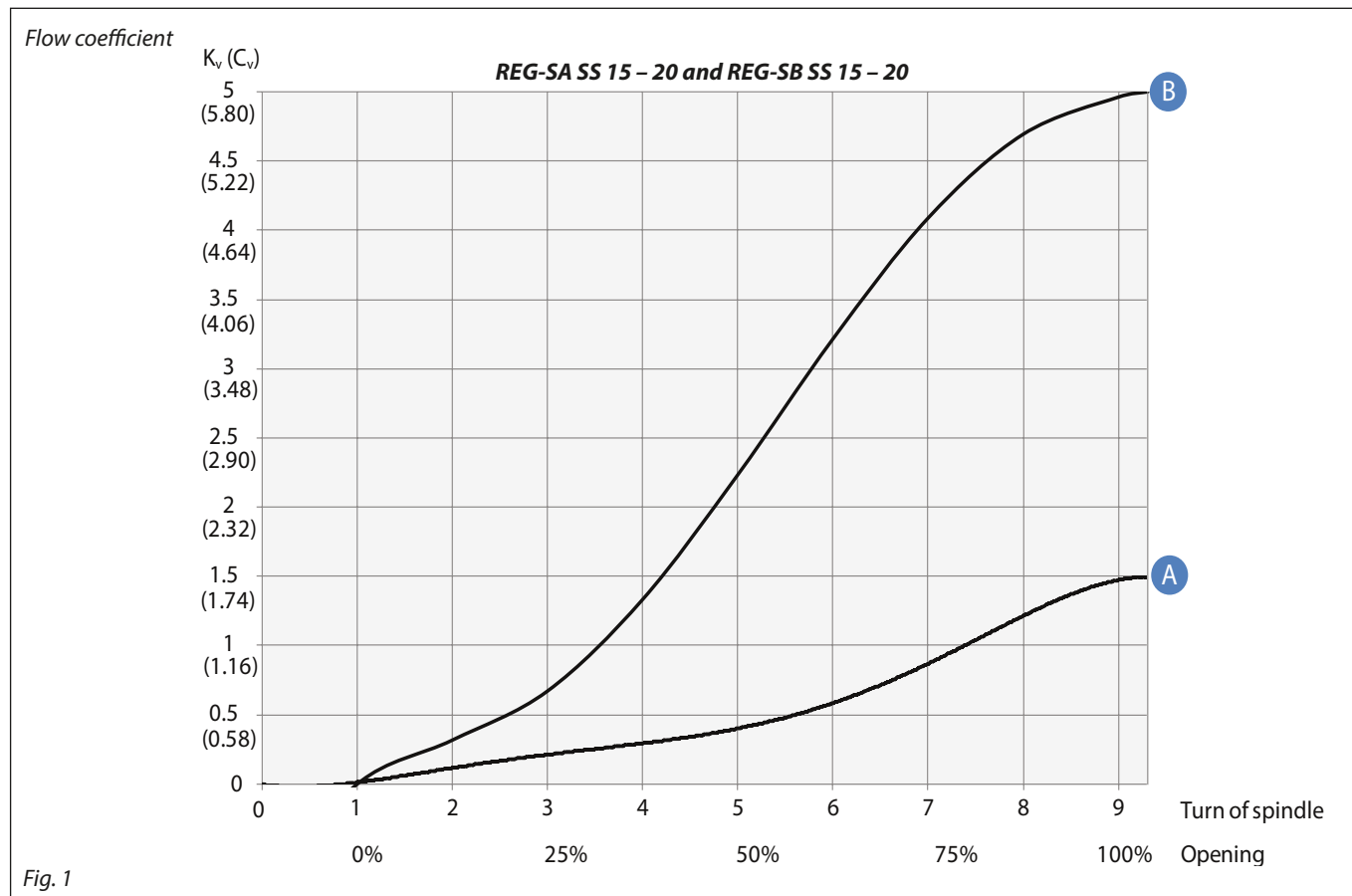

Computation and selection
(Continued)

Liquid R 717, density: 670 kg/m³ [42 lb/ft³]

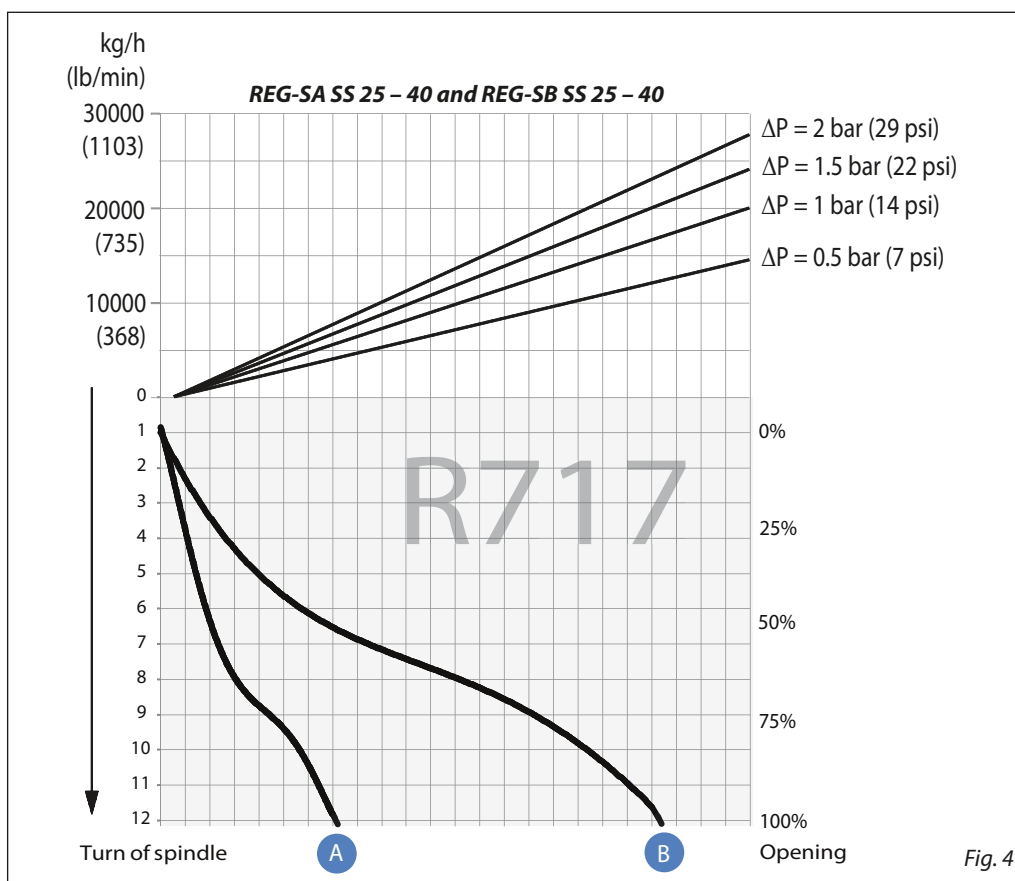
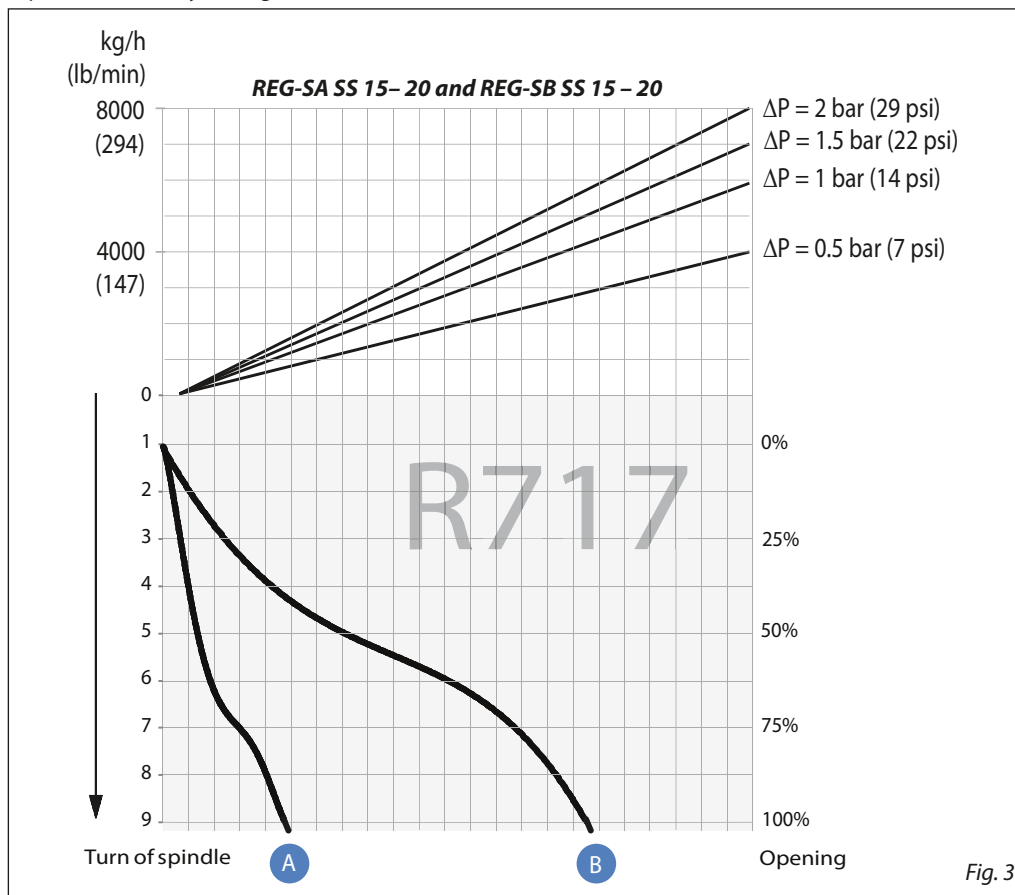

For choice of valve size and connection see "Connections".

Computation and selection
(Continued)

Calculation factor C_A

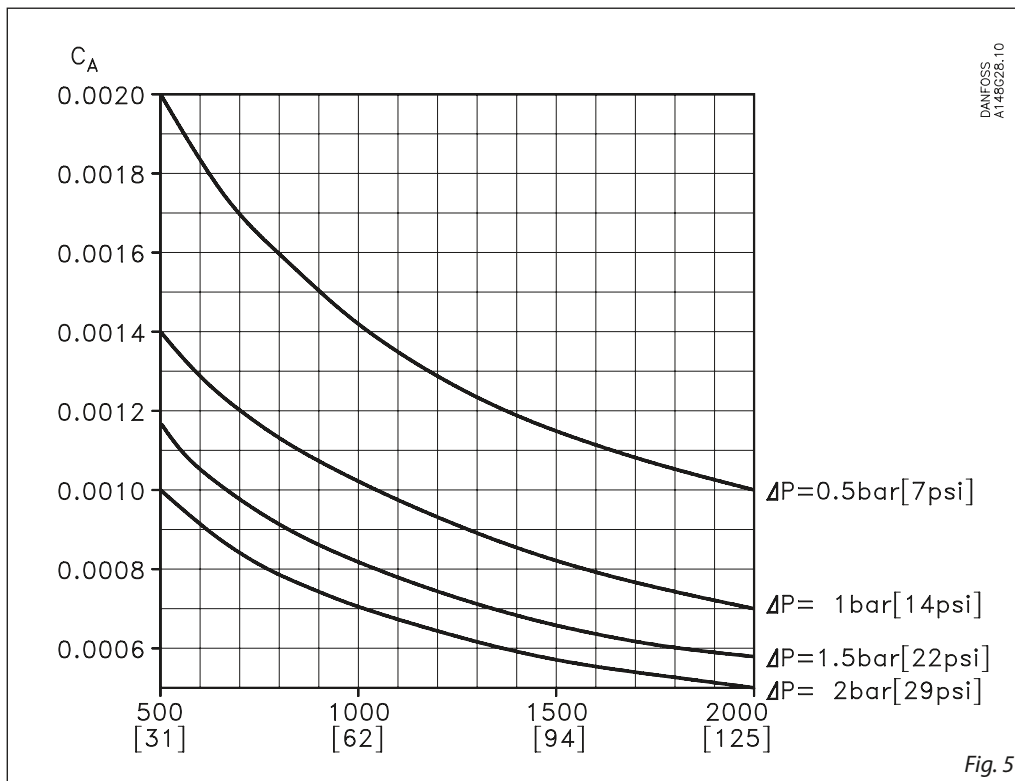

For choice of valve size and connection see "Connections".

Fig. 5

Data sheet | Stainless Steel Valves 15 (½ in.) - 125 (5 in.)

Computation and selection

Example 1.

Refrigerant: R 717
 Refrigerant flow: 2200 kg/h
 Pressure drop: $\Delta p = 0.5$ bar

The above mentioned example is illustrated on the following flow rate diagram and shows that REG-SB SS 15 and 20 with cone B can be used. The main rule is that nominal regulation range should be below 85% opening degree. If the arrowline is crossing 2 cone curves, the smaller cone should be selected if opening degree < 85%.

The example is only correct if the density of the refrigerant is approx. 670 (kg/m³), and there must be no build-up of flash gas in the valve.

Flow rate diagram

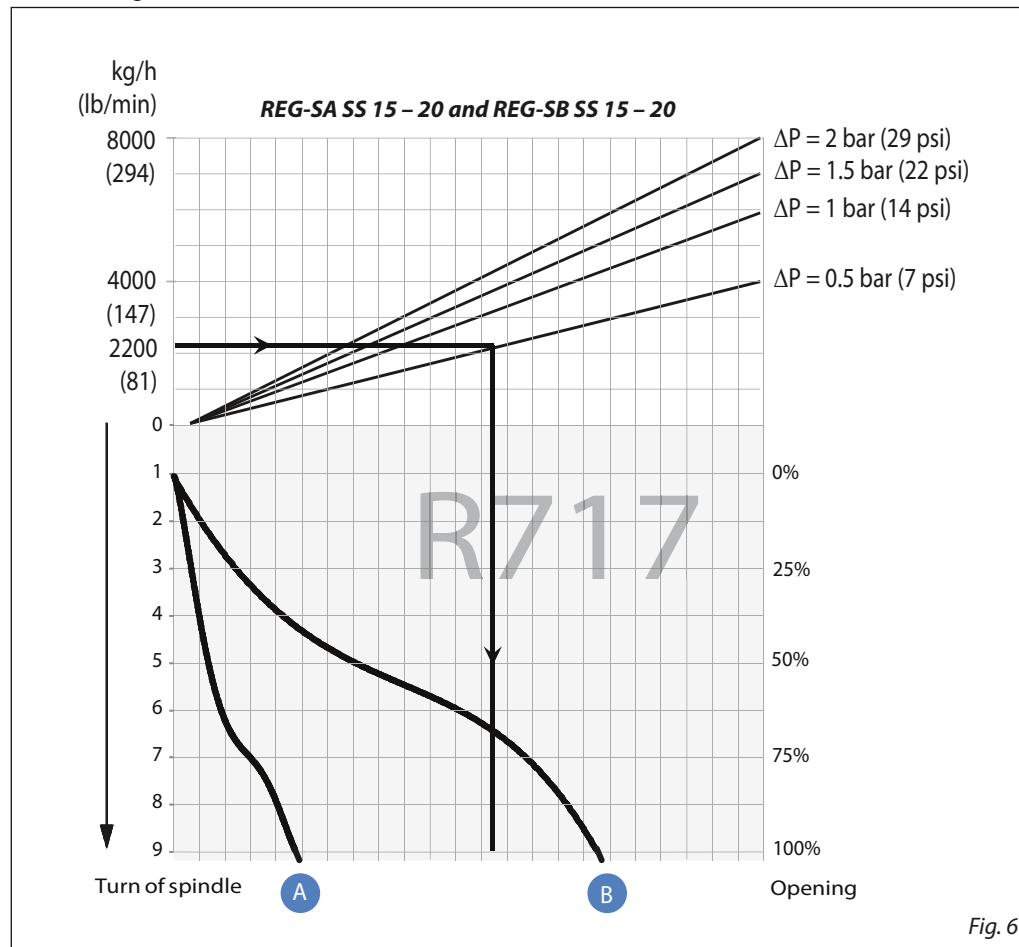

Computation and selection
Example 2.

Brine, density ρ : 1150 [kg/m³]
 Brine flow G : 2,700 [kg/h]
 Pressure drop Δp : 0.5 [bar]

In this example it is not possible to use the selection diagrams (fig. 3 and 4) as the refrigerant in question is not included.

Use the curves of the k_v -values instead (fig. 1 - 2) and calculate the required k_v by means of the formulas in the "Introduction" passage at the beginning of this chapter. Alternatively calculate the k_v -values by means of the calculation factor C_A (fig. 7) and the flow rate diagram (in this example: fig. 8) as per the following calculation example.

Calculation example:

Required k_v -value
 $C_A = 0.00132$ (from fig. 18)
 $k_v = C_A \times G$
 $k_v = 0.00132 \times 2,700$ [kg/h]
 $= 3.56$ [m³/h]

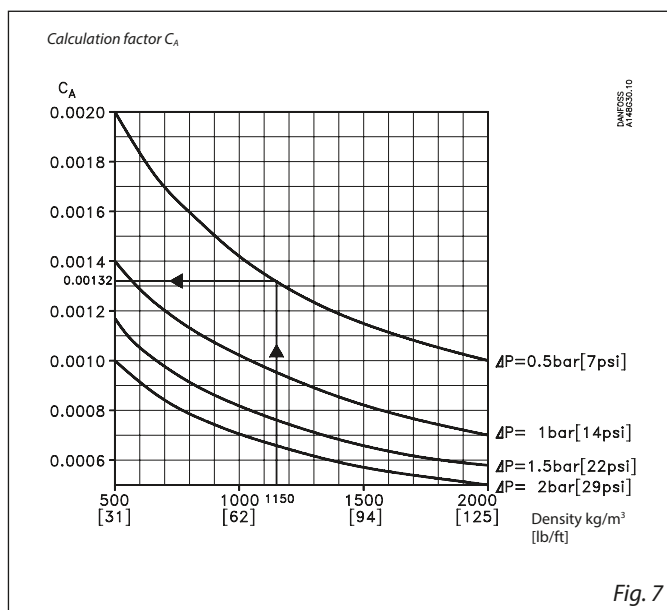

Fig. 7

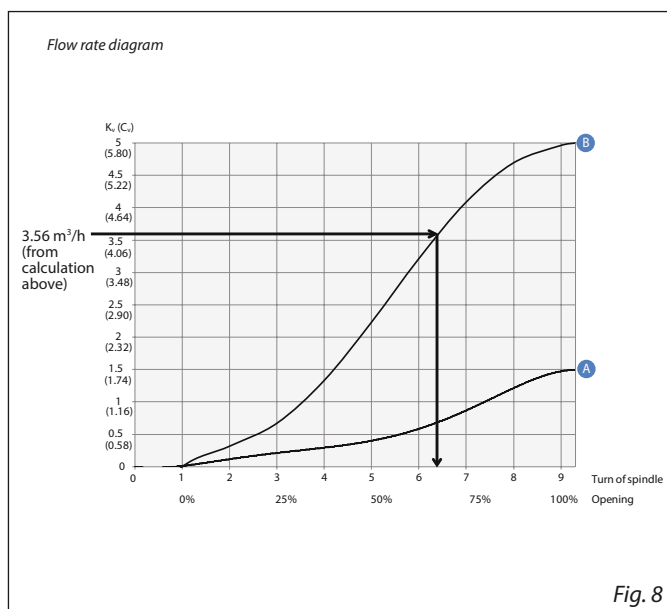
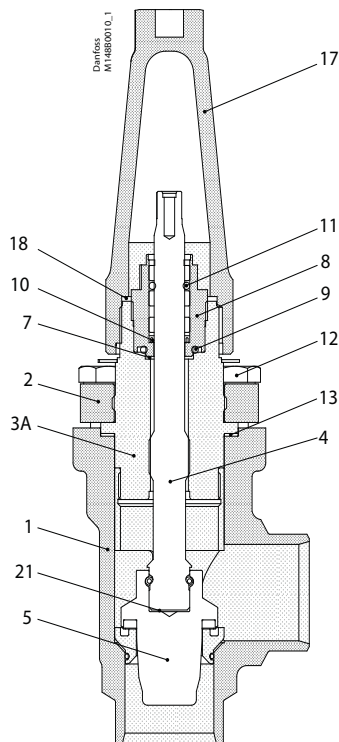

Fig. 8

REG-SB SS 15 and REG-SB SS 20 with cone B can be used.

Material specification

REG-SA SS and REG-SB SS 15 – 40



No.	Part	Material	EN	ISO	ASTM
1	Housing	Stainless steel	GX5CrNi19-10 EN10213-4		AISI 304
2	Bonnet, Flange	Stainless steel	X5CrNi18-10 EN10088		AISI 304
3A	Bonnet, Insert	Stainless steel	X8CrNiS18-9 DIN 17440		AISI 303
4	Spindle	Stainless steel	X8CrNiS 18-9, DIN 17440	Type 17, 683/13	AISI 303
5	Cone	Steel			
7	Packing washer	Aluminium			
8	Packing gland	Stainless Steel	X8CrNiS 18-9, 10088	Type 17, 683/13	AISI 303
9	O-ring	Cloroprene (Neoprene)			
10	Spring loaded Teflon ring	PTFE			
11	O-ring	Cloroprene (Neoprene)			
12	Bolts	Stainless steel	A2-70	A2-70	Type 308
13	Gasket	Fiber, non asbestos			
14	Bottom insert	Steel			
17	Seal cap	Aluminium			
18	Gasket f. seal cap	Nylon			
19	Locking nut	Steel			
20	Screw	Steel			
21	Disk spring	Steel			

Dimensions and weights

REG-SA SS and REG-SB SS 15 – 40 in angleway version

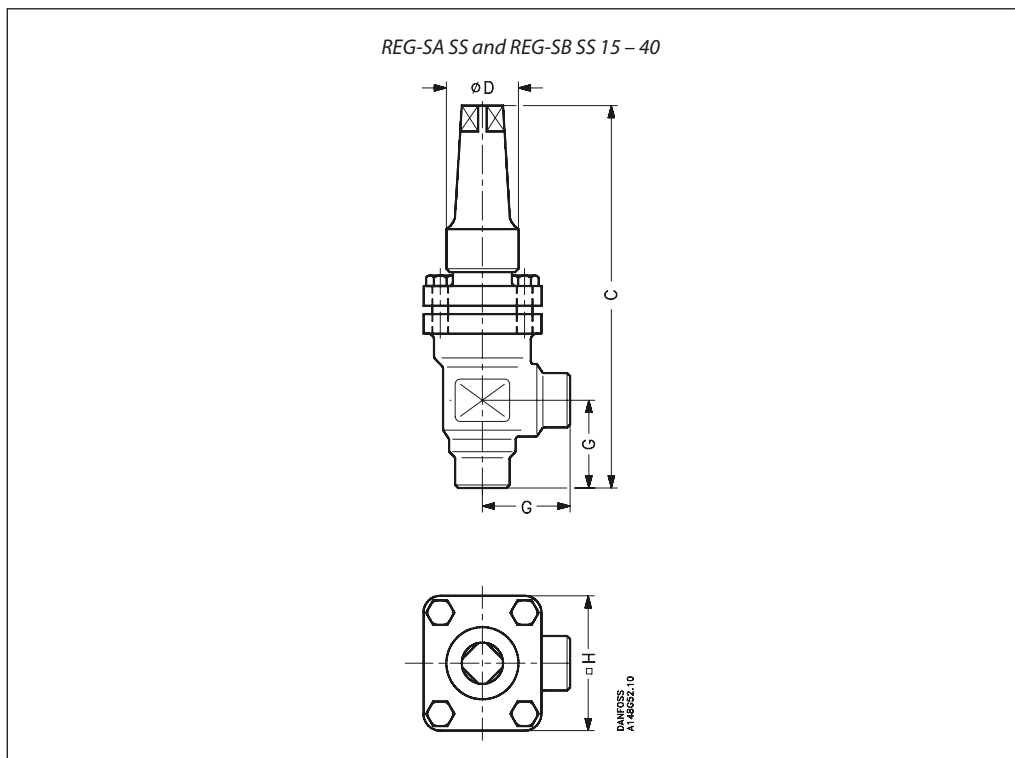

Valve size		C	G	$\varnothing D$	$\square H$	Weight
REG-SA SS/SB SS 15 – 20	mm	182	45	38	60	1.4 kg
REG-SA SS/SB SS (½ – ¾)	in.	7.17	1.77	1.50	2.36	3.1 lb
REG-SA SS/SB SS 25 – 40	mm	237	55	50	70	2.4 kg
REG-SA SS/SB SS (1 – 1½)	in.	9.33	2.17	1.97	2.76	5.3 lb

Specified weights are approximate values only.

REG-SA SS and REG-SB SS 10 – 65 in straightway version

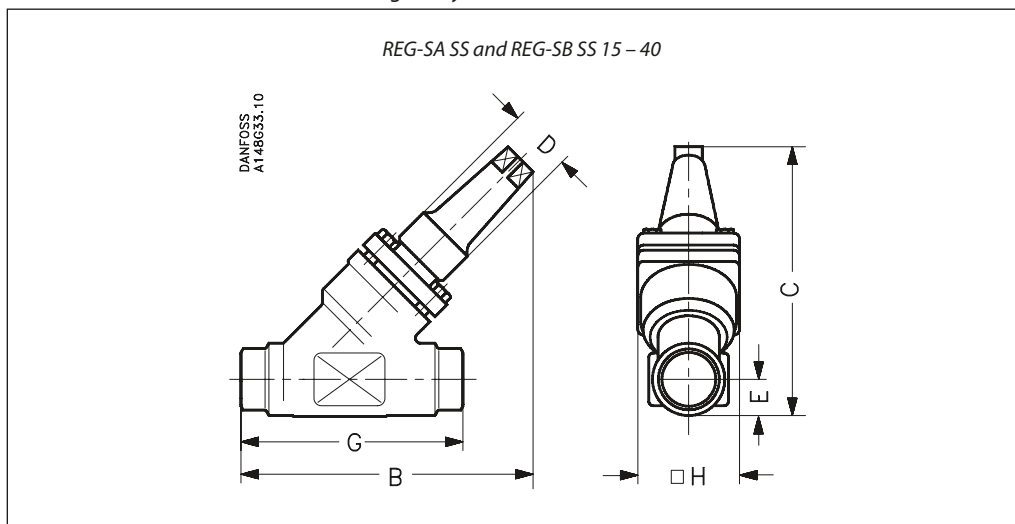

Valve size		C	B	E	G	$\varnothing D$	$\square H$	Weight
REG-SA SS/SB SS 15 – 20	mm	145	155	20	120	38	60	2.0 kg
REG-SA SS/SB SS (½ – ¾)	in.	5.71	6.10	0.79	4.72	1.50	2.36	4.4 lb
REG-SA SS/SB SS 25 – 40	mm	200	215	26	155	50	70	3.0 kg
REG-SA SS/SB SS (1 – 1½)	in.	7.87	8.46	1.02	6.10	1.97	2.76	6.6 lb

Specified weights are approximate values only.

Ordering
How to order

The table below is used to identify the valve required.

Please note that the type codes only serve to identify the valves, some of which may not form part of the standard product range. For further information please contact your local Danfoss Sales Company.

Type codes

Valve type	REG SA SS REG-SB SS	Regulating Valves	
Nominal size in mm (Valve size measured on the connection diameter)	15 20 25 32 40	DN 15 DN 20 DN 25 DN 32 DN 40	Available connection types D A x x x x x x x x x x
Connections	D A	Butt-weld connection: DIN EN 10220 Butt-weld connection: ANSI B 36.19M	
Valve housing	ANG STR	Angle flow Straight flow	
Cone A	Size: DN 15 DN 20 DN 25 DN 32 DN 40	Flow area [mm ²] 36.5 36.5 178 178 178	
Cone B	Size: DN 15 DN 20 DN 25 DN 32 DN 40	Flow area [mm ²] 115 115 531 531 531	

Complete REG-SA SS (Cone type A)
Example:

REG-SA SS (Cone B) 15 DIN angleway = **148B5387**

Important!

Where products need to be certified according to specific certification societies or where higher pressures are required, the relevant information should be included at the time of order.

Butt-weld DIN (EN 10220)

Size		Type	Code no.
mm	in.		
15	½	REG-SA SS 15 D ANG	148B5297
20	¾	REG-SA SS 20 D ANG	148B5385
25	1	REG-SA SS 25 D ANG	148B5494
32	1 ¼	REG-SA SS 32 D ANG	148B5589
40	1 ½	REG-SA SS 40 D ANG	148B5674

Angleway - REG-SA SS with cone type A

15	½	REG-SA SS 15 D ANG	148B5297
20	¾	REG-SA SS 20 D ANG	148B5385
25	1	REG-SA SS 25 D ANG	148B5494
32	1 ¼	REG-SA SS 32 D ANG	148B5589
40	1 ½	REG-SA SS 40 D ANG	148B5674

Butt-weld DIN (EN 10220)

Size		Type	Code no.
mm	in.		
15	½	REG-SA SS 15 D STR	148B5298
20	¾	REG-SA SS 20 D STR	148B5386
25	1	REG-SA SS 25 D STR	148B5495
32	1 ¼	REG-SA SS 32 D STR	148B5590
40	1 ½	REG-SA SS 40 D STR	148B5675

Straightway - REG-SA SS with cone type A

15	½	REG-SA SS 15 D STR	148B5298
20	¾	REG-SA SS 20 D STR	148B5386
25	1	REG-SA SS 25 D STR	148B5495
32	1 ¼	REG-SA SS 32 D STR	148B5590
40	1 ½	REG-SA SS 40 D STR	148B5675

Butt-weld ANSI (B 36.19M SCHEDULE 40)

Size		Type	Code no.
mm	in.		
15	½	REG-SA SS 15 A40 ANG	148B6482
25	1	REG-SA SS 25 A40 ANG	148B6483
32	1 ¼	REG-SA SS 32 A40 ANG	148B6484

Angleway - REG-SA SS with cone type A

15	½	REG-SA SS 15 A40 ANG	148B6482
25	1	REG-SA SS 25 A40 ANG	148B6483
32	1 ¼	REG-SA SS 32 A40 ANG	148B6484

Butt-weld ANSI (B 36.19M SCHEDULE 40)

Size		Type	Code no.
mm	in.		
15	½	REG-SA SS 15 A40 STR	148B5299
25	1	REG-SA SS 25 A40 STR	148B6485
32	1 ¼	REG-SA SS 32 A40 STR	148B6486

Straightway - REG-SA SS with cone type A

15	½	REG-SA SS 15 A40 STR	148B5299
25	1	REG-SA SS 25 A40 STR	148B6485
32	1 ¼	REG-SA SS 32 A40 STR	148B6486

D = Butt-weld DIN
A = Butt-weld ANSI
ANG = Angleway
STR = Straightway

Ordering

Complete REG-SB SS (Cone type B)

Butt-weld DIN (EN 10220)

Size		Type	Code no.
mm	in.		

Angleway - REG-SB SS with cone type B

15	½	REG-SB SS 15 D ANG	148B5387
20	¾	REG-SB SS 20 D ANG	148B5389
25	1	REG-SB SS 25 D ANG	148B5496
32	1 ¼	REG-SB SS 32 D ANG	148B5591
40	1 ½	REG-SB SS 40 D ANG	148B5676

Butt-weld DIN (EN 10220)

Size		Type	Code no.
mm	in.		

Straightway - REG-SB SS with cone type B

15	½	REG-SB SS 15 D STR	148B5388
20	¾	REG-SB SS 20 D STR	148B5390
25	1	REG-SB SS 25 D STR	148B5497
32	1 ¼	REG-SB SS 32 D STR	148B5592
40	1 ½	REG-SB SS 40 D STR	148B5677

Butt-weld ANSI (B 36.19M SCHEDULE 40)

Size		Type	Code no.
mm	in.		

Angleway - REG-SB SS with cone type B

20	¾	REG-SB SS 20 A40 ANG	148B6487
40	1 ½	REG-SB SS 40 A40 ANG	148B5686

Butt-weld ANSI (B 36.19M SCHEDULE 40)

Size		Type	Code no.
mm	in.		

Straightway - REG-SB SS with cone type B

20	¾	REG-SB SS 20 A40 STR	148B6488
25	1	REG-SB SS 25 A40 STR	148B6479
40	1 ½	REG-SB SS 40 A40 STR	148B5685

- D = Butt-weld DIN
- A = Butt-weld ANSI
- ANG = Angleway
- STR = Straightway

**Check & stop valves and check valves
SCA-X SS and CHV-X SS**

In certain specific areas such as outdoor applications and corrosive atmospheres, such as coastal installations, there is a need for high surface protection to prevent failure due to corrosion.

Today's food safety standards often call for daily treatment with detergents to protect against bacteria growth, again producing a need for high surface protection.

SCA-X SS are check valves with a built-in stop valve function. CHV-X SS are check valves only.

The valves are designed to open at very low differential pressures, allow favourable flow conditions and are easy to disassemble for inspection and service.

The valve cone has a built-in flexibility to ensure a precise and tight closing towards the valve seat.

A well balanced dampening effect between the piston and the cylinder gives an optimal protection during low loads and against pulsations.



**Features
SCA-X SS and CHV-X SS**

- Applicable to HCFC, HFC, R717 (Ammonia), R744 (CO₂), Propane, Butane, Iso-Butane and Ethane.
- Designed to give favourable flow conditions.
- Internal backseating enables replacement of the spindle seal whilst the valve is active, i.e. under pressure (SCA-SS)
- Housing is made of special cold resistant stainless steel approved for low temperature operations.
- Easy to disassemble for inspection and service.
- Butt-weld DIN and ANSI connections.
- Max. operating pressure: 52 bar g / 754 psig
- Temperature range: -60 – 150 °C / -76 – 302 °F.
- Compact and light valves for easy handling and installation.
- Classification: DNV, CRN, BV, EAC etc. To get an updated list of certification on the products please contact your local Danfoss Sales Company.

Pressure and temperature range

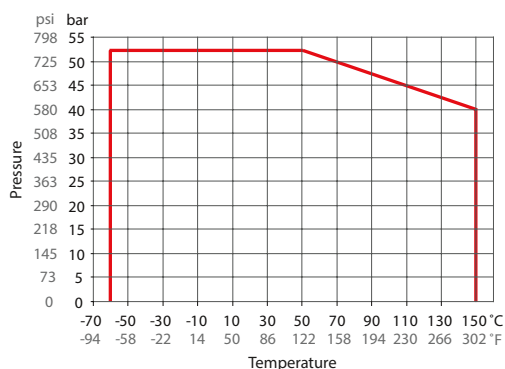

— SCA-X SS/CHV-X SS DN15-DN40

Technical data

- **Refrigerants**
Applicable to HCFC, HFC, R717 (Ammonia), R744 (CO₂), Propane, Butane, Iso-Butane and Ethane.
For further information refer to the product instruction for SCA-X SS/CHV-X SS.
- **Temperature range**
-60 – 150 °C / -76 – 302 °F.
- **Max. working pressure**
52 bar g / 754 psig.

Design

Connections

Available with the following connections:

- Butt-weld DIN (EN 10220)
DN 15 - 40 (½ – 1 ½ in.)
- Butt-weld ANSI (B 36.19M)
DN 20 - 40 (¾ – 1 ½ in.)

Housing

Made of stainless steel approved for low temperature operations.

Valve cone

Valve cone with built in metallic stop - prevents damage to teflon ring in case of overtightening.

Damping chamber

The chamber is filled with refrigerants (gas or liquid), which provides a damping effect when the valve opens and closes.

Spindle (SCA-X SS)

Made of polished stainless steel, which is ideal for O-ring sealing.

Packing Gland (SCA-X SS)

The "full temperature range" packing gland is the standard for the entire SVL platform.

This ensures perfect tightness throughout the whole temperature range:
-60 – 150 °C / -76 – 302 °F.

Pressure Equipment Directive (PED)

The SCA-X SS/CHV-X SS valves are approved according to the European standard specified in the Pressure Equipment Directive and are CE marked.

Installation

The valve must be mounted vertically with the cone downwards.

The valve is designed to resist very high internal pressure. However, the piping system in general should be designed to avoid liquid traps and reduce the risk of hydraulic pressure caused by thermal expansion.

For further information refer to installation instructions for SCA-X SS/CHV-X SS.

If cold refrigeration oil having low viscosity enters and settles in the damping chamber, problems with the check valve may arise. Consequently, it may be necessary to modify the valve for more viscous liquids by enlarging the hole to the damping chamber.

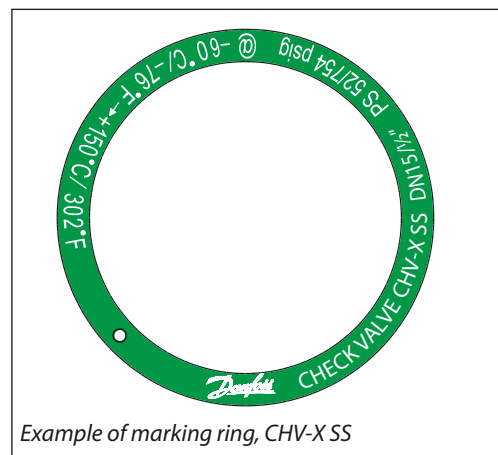

Example of marking ring, CHV-X SS

For further details / restrictions - see the product instruction.



SCA-X SS/CHV-X SS valves		
Nominal bore	DN = < 25 mm (1 in.)	DN32 – 40 mm (1 ¼ – 1 ½ in.)
Classified for	Fluid group I	
Category	Article 3, paragraph 3	II

Connections

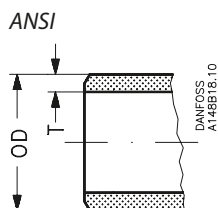
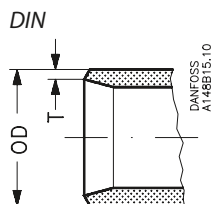

Size	OD	T
Butt-weld DIN (EN 10220)		
15 mm	21.3	2.3
½ in.	0.839	0.091
20 mm	26.9	2.3
¾ in.	1.059	0.091
25 mm	33.7	2.6
1 in.	1.327	0.103
32 mm	42.4	2.6
1 ¼ in.	1.669	0.102
40 mm	48.3	2.6
1 ½ in.	1.902	0.103

Size	OD	T
Butt-weld ANSI (B 36.19M), SCHEDULE 40		
20 mm	26.9	2.9
¾ in.	1.06	0.11
25 mm	33.7	3.5
1 in.	1.33	0.14
32 mm	42.4	3.6
1 ¼ in.	1.67	0.14
40 mm	48.3	3.7
1 ½ in.	1.9	0.15

Material specification

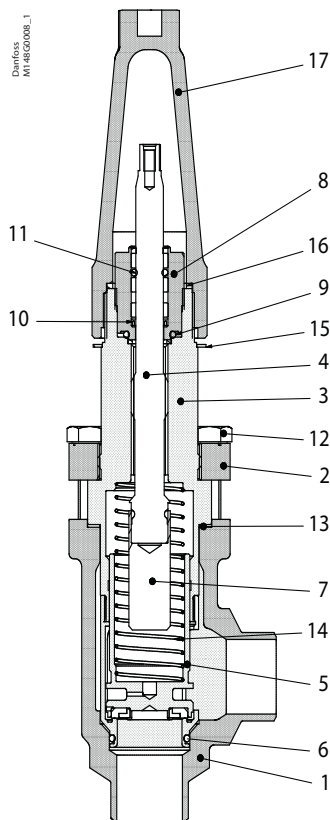

SCA-X SS 15 - 40

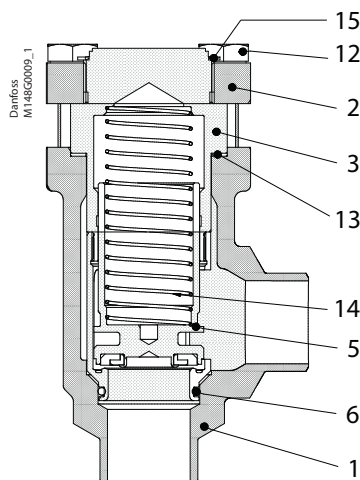

CHV-X SS 15 - 40

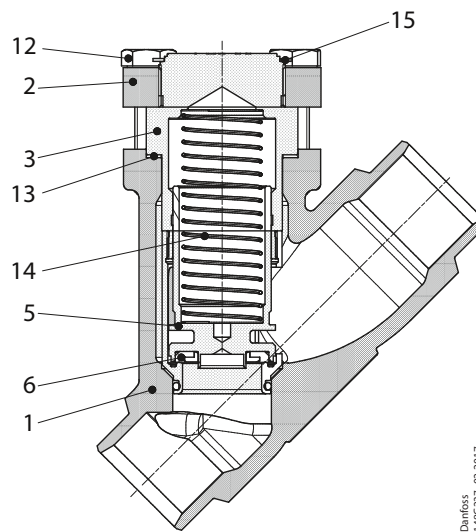

CHV-X SS 15 - 40

No.	Part	Material	DIN/EN	ISO	ASTM
1	Housing	Stainless steel	GX5CrNi19-10 EN10213-4		AISI 304
2	Bonnet, Flange	Stainless steel	X5CrNi18-10 EN10088		AISI 304
3	Bonnet, Insert	Stainless steel	X8CrNiS18-9 DIN 17440		
4	Spindle	Stainless steel	X8CrNiS18-9 DIN 17440	Type 17, 17440	AISI 303
5	Cone	Steel Teflon (PTFE)			
6	O-ring	Cloroprene (Neoprene)			
7	Spindle extension	Steel			
8	Packing gland O-rings	Stainless steel Cloroprene (Neoprene)			
9	Packing washer	Aluminium			
10	Spring loaded seal	Teflon (PTFE)			
11	O-ring	Cloroprene (Neoprene)			
12	Bolts	Stainless steel	A2-70	A2-70	Type 308
13	Gasket	Fiber, non-asbestos			
14	Spring	Steel			
15	Identification ring	Stainless steel			
16	Seal cap gasket	Nylon			
17	Spindle seal cap	Aluminium			

Dimensions and weights

SCA-X SS/CHV-X SS 15 – 40 (½ – 1 ½ in.)

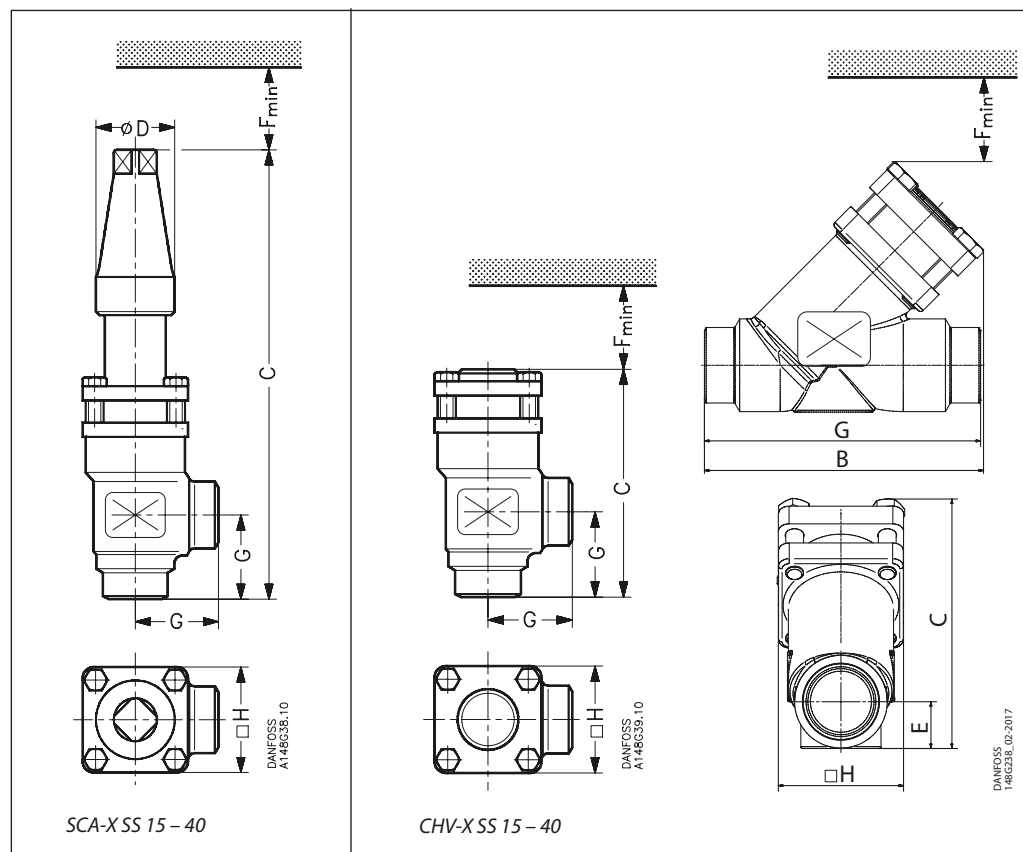

Valve size	C	G	ØD	F _{min}	□H	Weight
------------	---	---	----	------------------	----	--------

SCA-X SS 15 – 40

SCA-X SS 15 (½ in.)	mm in.	212 8.35	45 1.77	38 1.50	60 2.36	60 2.36	1.6 kg 3.53 lb
SCA-X SS 20 (¾ in.)	mm in.	212 8.35	45 1.77	38 1.50	60 2.36	60 2.36	1.6 kg 3.53 lb
SCA-X SS 25 (1 in.)	mm in.	295 11.61	55 2.17	50 1.97	85 3.35	70 2.76	3.2 kg 7.05 lb
SCA-X SS 32 (1 ¼ in.)	mm in.	295 11.61	55 2.17	50 1.97	85 3.35	70 2.76	3.2 kg 7.05 lb
SCA-X SS 40 (1 ½ in.)	mm in.	295 11.61	55 2.17	50 1.97	85 3.35	70 2.76	3.2 kg 7.05 lb

CHV-X SS 15 – 40 Angleway

CHV-X SS 15 (½ in.)	mm in.	103 4.06	45 1.77		60 2.36	60 2.36	1.2 kg 2.65 lb
CHV-X SS 20 (¾ in.)	mm in.	103 4.06	45 1.77		60 2.36	60 2.36	1.2 kg 2.65 lb
CHV-X SS 25 (1 in.)	mm in.	143 5.63	55 2.17		85 3.35	70 2.76	2.3 kg 5.07 lb
CHV-X SS 32 (1 ¼ in.)	mm in.	143 5.63	55 2.17		85 3.35	70 2.76	2.3 kg 5.07 lb
CHV-X SS 40 (1 ½ in.)	mm in.	143 5.63	55 2.17		85 3.35	70 2.76	2.3 kg 5.07 lb

Valve size	C	B	E	G	F _{min}	□H	Weight
------------	---	---	---	---	------------------	----	--------

CHV-X SS 15 – 40 Straightway

CHV-X SS 15 (½ in.)	mm in.	99 3.90	114 4.49	19 0.75	120 4.72	60 2.36	60 2.36	1.3kg 2.87lb
CHV-X SS 20 (¾ in.)	mm in.	99 3.90	114 4.49	19 0.75	120 4.72	60 2.36	60 2.36	1.3kg 2.87lb
CHV-X SS 25 (1 in.)	mm in.	141 5.55	157 6.18	26 1.02	155 6.10	85 3.35	70 2.76	2.6kg 5.73lb
CHV-X SS 32 (1 ¼ in.)	mm in.	141 5.55	157 6.18	26 1.02	155 6.10	85 3.35	70 2.76	2.6kg 5.73lb
CHV-X SS 40 (1 ½ in.)	mm in.	141 5.55	157 6.18	26 1.02	155 6.10	85 3.35	70 2.76	2.6kg 5.73lb

Specified weights are approximate values only.

Data sheet | Stainless Steel Valves 15 (½ in.) - 125 (5 in.)

Ordering complete valves

How to order

The table below is used to identify the valve required.

For further information please contact your local Danfoss Sales Company.

Please note that the type codes only serve to identify the valves, some of which may not form part of the standard product range.

Valve type	SCA-X SS CHV-X SS	Stop Check Valve Check Valve		
(valve size measured on the connection diameter)	15	DN 15	D x	A
	20	DN 20	x	x
	25	DN 25	x	x
	32	DN 32	x	x
	40	DN 40	x	x
Connections	D A	Butt-weld connection: DIN EN 10220 Butt-weld connection: ANSI B 36.19M		
Valve housing	ANG STR	Angle flow Straight flow		

Important!

Where products need to be certified according to specific certification societies, or where higher pressures are required, the relevant information should be included at the time of order.

SCA-X SS Angleway

Butt-weld DIN (EN 10220)

Size		Type	Code No.
mm	in.		
15	½	SCA-X SS 15 D ANG	148B5293
20	¾	SCA-X SS 20 D ANG	148B5381
25	1	SCA-X SS 25 D ANG	148B5490
32	1 ¼	SCA-X SS 32 D ANG	148B5585
40	1 ½	SCA-X SS 40 D ANG	148B5664

Butt-weld ANSI (B 36.19M SCHEDULE 40)

Size		Type	Code No.
mm	in.		
20	¾	SCA-X SS 20 A40 ANG	148B6489
25	1	SCA-X SS 25 A40 ANG	148B6480
32	1 ¼	SCA-X SS 32 A40 ANG	148B6490
40	1 ½	SCA-X SS 40 A40 ANG	148B5687

CHV-X SS Angleway

Butt-weld DIN (EN 10220)

Size		Type	Code No.
mm	in.		
15	½	CHV-X SS 15 D ANG	148B5294
20	¾	CHV-X SS 20 D ANG	148B5382
25	1	CHV-X SS 25 D ANG	148B5491
32	1 ¼	CHV-X SS 32 D ANG	148B5586
40	1 ½	CHV-X SS 40 D ANG	148B5665

Butt-weld ANSI (B 36.19M SCHEDULE 40)

Size		Type	Code No.
mm	in.		
20	¾	CHV-X SS 20 A40 ANG	148B6491
25	1	CHV-X SS 25 A40 ANG	148B6481
32	1 ¼	CHV-X SS 32 A40 ANG	148B6492
40	1 ½	CHV-X SS 40 A40 ANG	148B5688

ANG = Angleway
STR = Straightway

CHV-X SS Straightway

Butt-weld DIN (EN 10220)

Size		Type	Code No.
mm	in.		
15	½	CHV-X SS 15 D STR	148B5678
20	¾	CHV-X SS 20 D STR	148B5679
25	1	CHV-X SS 25 D STR	148B5680
32	1 ¼	CHV-X SS 32 D STR	148B6544
40	1 ½	CHV-X SS 40 D STR	148B6566

Butt-weld ANSI (B 36.19M SCHEDULE 40)

Size		Type	Code No.
mm	in.		
20	¾	CHV-X SS 20 A40 STR	148B6608
25	1	CHV-X SS 25 A40 STR	148B6609
32	1 ¼	CHV-X SS 32 A40 STR	148B6610
40	1 ½	CHV-X SS 40 A40 STR	148B6611

Strainers
FIA SS

In certain specific areas such as outdoor applications and corrosive atmospheres, such as coastal installations, there is a need for high surface protection to prevent failure due to corrosion.

Today's food safety standards often call for daily treatment with detergents to protect against bacteria growth, again producing a need for high surface protection.

FIA SS strainers are a range of angle-way and straight-way strainers which are carefully designed to give favourable flow conditions.

The design makes the strainer easy to install, and ensures quick strainer inspection and cleaning.

FIA SS strainers are used ahead of automatic controls, pumps, compressors etc., for initial plant start-up and where permanent filtration of the refrigerant is required. The strainer reduces the risk of undesirable system breakdowns and reduces wear and tear on plant components.



Features
FIA SS

- Applicable to HCFC, HFC, R717 (Ammonia), R744 (CO₂) and all flammable refrigerants.
- Designed to give favourable flow conditions.
- Housing is made of special cold resistant stainless steel approved for low temperature operations.
- Easy to disassemble for inspection and service.
- Butt-weld DIN and ANSI connections.
- Max. operating pressure: 52 bar g / 754 psig
- Temperature range: -60 – 150 °C / -76 – 302 °F.
- Compact and light valves for easy handling and installation.
- Classification: DNV, CRN, BV, EAC etc. To get an updated list of certification on the products please contact your local Danfoss Sales Company.

Pressure and temperature range

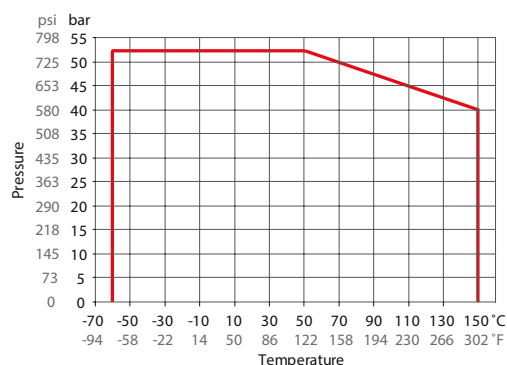

FIA SS DN15-DN65

Technical data

- **Refrigerants**
Applicable to HCFC, HFC, R717 (Ammonia), R744 (CO₂) and all flammable refrigerants. For further information please see installation guide for FIA SS.
- **Temperature range**
-60 °C – 150 °C / -76 °F – 302 °F.
- **Max. working pressure:**
52 bar g / 754 psi g.

Design

Connections

Available with the following connections:

- Butt-weld DIN (EN 10220)
DN 15 - 65 (½ – 2 ½ in.)
- Butt-weld ANSI (B 36.19M)
DN 15 - 65 (½ – 2 ½ in.)

Strainer Insert

A filter grid and filter net of stainless steel ensure long element life. The filter net offers a very high degree of cleanability.

Housing

Made of stainless steel approved for low temperature operations.

Pressure Equipment Directive (PED)

FIA SS strainers are approved in accordance with the European standard specified in the Pressure Equipment Directive and are CE marked. For further details / restrictions - see Installation Instruction.

Installation / Maintenance

The strainer is designed to resist high internal pressures. However, the piping system in general should be designed to avoid liquid traps and reduce the risk of hydraulic pressure caused by thermal expansion.

Install the strainer with the cover in downward position.

Danfoss recommends replacement/cleaning of the strainer when the differential pressure loss >0.5 bar / 7.3 psi in the liquid line and >0.05 bar / 0.7 psi in the suction line. The max. permissible differential pressure is 1 bar / 15 psi.

For further information refer to installation instruction for FIA SS.

Identification:

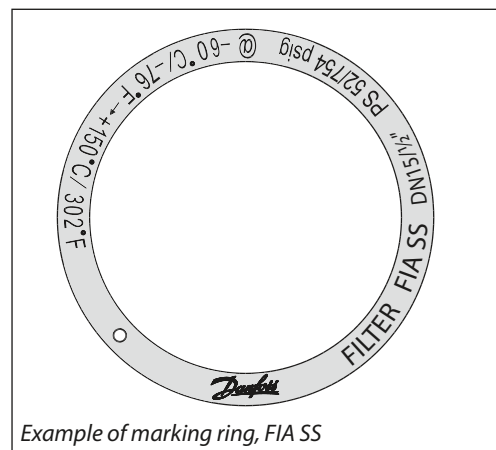

FIA SS		
Nominal bore	DN ≤ 25 (1 in.)	DN 32-65 mm (1 ¼ – 2 ½ in.)
Classified for	Fluid group I	
Category	Article 3, paragraph 3	II

Connections

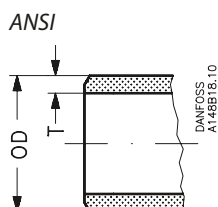
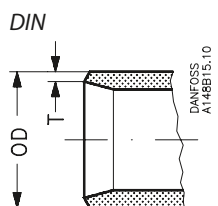

Size		OD	T
Butt-weld DIN (EN 10220)			
15	mm	21.3	2.3
½	in.	0.839	0.091
20	mm	26.9	2.3
¾	in.	1.059	0.091
25	mm	33.7	2.6
1	in.	1.327	0.103
32	mm	42.4	2.6
1 ¼	in.	1.669	0.102
40	mm	48.3	2.6
1 ½	in.	1.902	0.103
50	mm	60.3	2.9
2	in.	2.37	0.11
65	mm	76.1	2.9
2 ½	in.	3	0.11

Size		OD	T
Butt-weld ANSI (B 36.19M)			
15	mm	21.3	2.8
½	in.	0.839	0.11
20	mm	26.9	2.9
¾	in.	1.06	0.11
25	mm	33.7	3.5
1	in.	1.33	0.14
32	mm	42.4	3.6
1 ¼	in.	1.67	0.14
40	mm	48.3	3.7
1 ½	in.	1.9	0.15
50	mm	60.3	2.8
2	in.	2.37	0.11
65	mm	73	3.1
2 ½	in.	2.87	0.12

Data sheet | Stainless Steel Valves 15 (½ in.) - 125 (5 in.)

Selection of strainer size

The mesh aperture size of the strainer must satisfy the requirements stated by the suppliers of the equipment to be protected.

The following recommendations of aperture size apply in general to refrigeration installations:

All lines

First start up: **50μ**
 (Use filter element with removable insert for FIA SS DN15-40 or separate filter bag for FIA SS DN 50-65. 50μ insert should normally be removed after the first 24 hours of operation)

Liquid Lines

Ahead of pumps: **500μ** [38 mesh]
 After pumps: **150μ** [100 mesh] / 250μ [72 mesh]
 In front of AKVA valves **100μ** [150 mesh]

Protection of automatic regulation equipment

Generally **150μ** [100 mesh] / 250μ [72 mesh]
 Sensitive equipment, e.g.
 suction regulators with low temperature **250μ** [72 mesh]

Definition

Mesh is the number of threads per inch.
 μ (microns) is the distance between two threads (1μ = 1 / 1000 mm).

Suction Lines

Ahead of screw compressor **250μ** [72 mesh]
 Ahead of piston compressor **150μ** [100 mesh]

Flow coefficient (DIN/ANSI)

Connection size (DN)	μ	mesh	wire mm	wire in.	free space %	screen area			
						Plain elements		Pleated elements	
						cm ²	in ²	cm ²	in ²
FIA SS 15 – 20 (½" – ¾")	100		0.068	0.003	35	25	3.9	45	7.0
	150	100	0.10	0.004	36	25	3.9	45	7.0
	250	72	0.10	0.004	51	25	3.9	45	7.0
	500	38	0.16	0.006	57.6	25	3.9	45	7.0
25 - 40 (1" – 1 ½")	100		0.068	0.003	35	71	11	160	25.0
	150	100	0.10	0.004	36	71	11	160	25.0
	250	72	0.10	0.004	51	71	11	160	25.0
	500	38	0.16	0.006	57.6	71	11	160	25.0
50 (2")	100		0.068	0.003	35	71	11	200	31.2
	150	100	0.10	0.004	36	87	13.5	200	31.2
	250	72	0.10	0.004	51	87	13.5	200	31.2
	500	38	0.16	0.006	57.6	87	13.5	200	31.2
65 (2 ½")	150	100	0.10	0.004	36	127	19.7	305	47.6
	250	72	0.10	0.004	51	127	19.7	305	47.6
	500	38	0.16	0.006	57.6	127	19.7	305	47.6

K_v values

DN	FIA SS angle - plain filter net				FIA SS angle - pleated filter net		
	μ100	μ150	μ250	μ500	μ150	μ250	μ500
15	3.3	3.4	3.5	3.7	4.2		
20	6.9	7.1	7.3	7.7	8.8		
25	13.8	14.0	14.5	15.2	17.2	17.9	
32	23.0	23.8	24.7	25.5	29.2	30.5	
40	25.1	25.5	26.4	28.1	31.4	32.6	
50	45.1	45.9	47.6	50.2	56.7	58.8	62.0
65		56.1	57.8	60.4	69.3	71.4	74.6

DN	FIA SS straight - plain filter net				FIA SS straight - pleated filter net		
	μ100	μ150	μ250	μ500	μ150	μ250	μ500
15	2.5	2.6	2.7	2.8	3.3		
20	5.3	5.4	5.6	5.9	6.9		
25	10.5	10.7	11.1	11.6	13.8	14.5	
32	17.6	18.2	18.9	19.5	23.9	24.7	
40	19.2	19.5	20.2	21.5	25.5	26.4	
50	34.5	35.1	36.4	38.4	45.9	47.6	50.2
65		42.9	44.2	46.2	56.1	57.8	60.4

Material specification

FIA SS 15 – 65 (1/2 in. – 2 1/2 in.)

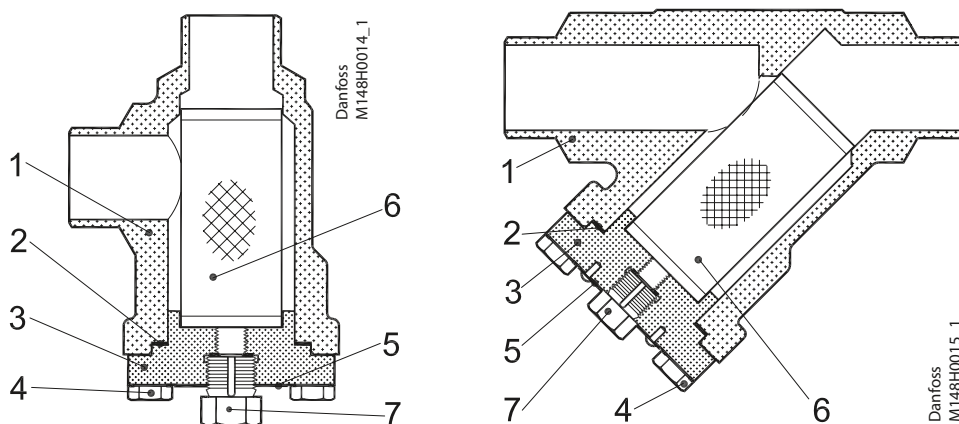

FIA SS 15 – 65 (1/2 in. – 2 1/2 in.)

No.	Part	Material	DIN	ISO	ASTM
1	Housing	Stainless steel (FIA SS only)	GX5CrNi19-10 EN10213-4		AISI 304
2	Gasket	Fibre, Non-asbestos			
3	Cover	Stainless steel (FIA SS only)	GX5CrNi19-10 EN10213-4		AISI 304
4	Bolts	Stainless steel	A2-70	A2-70	Type 308
5	Marking label	Aluminium			
6	Filter element	Stainless steel			
7	Pressure relief (screw)	Stainless steel			

Dimensions and weights

FIA SS 15 – 65

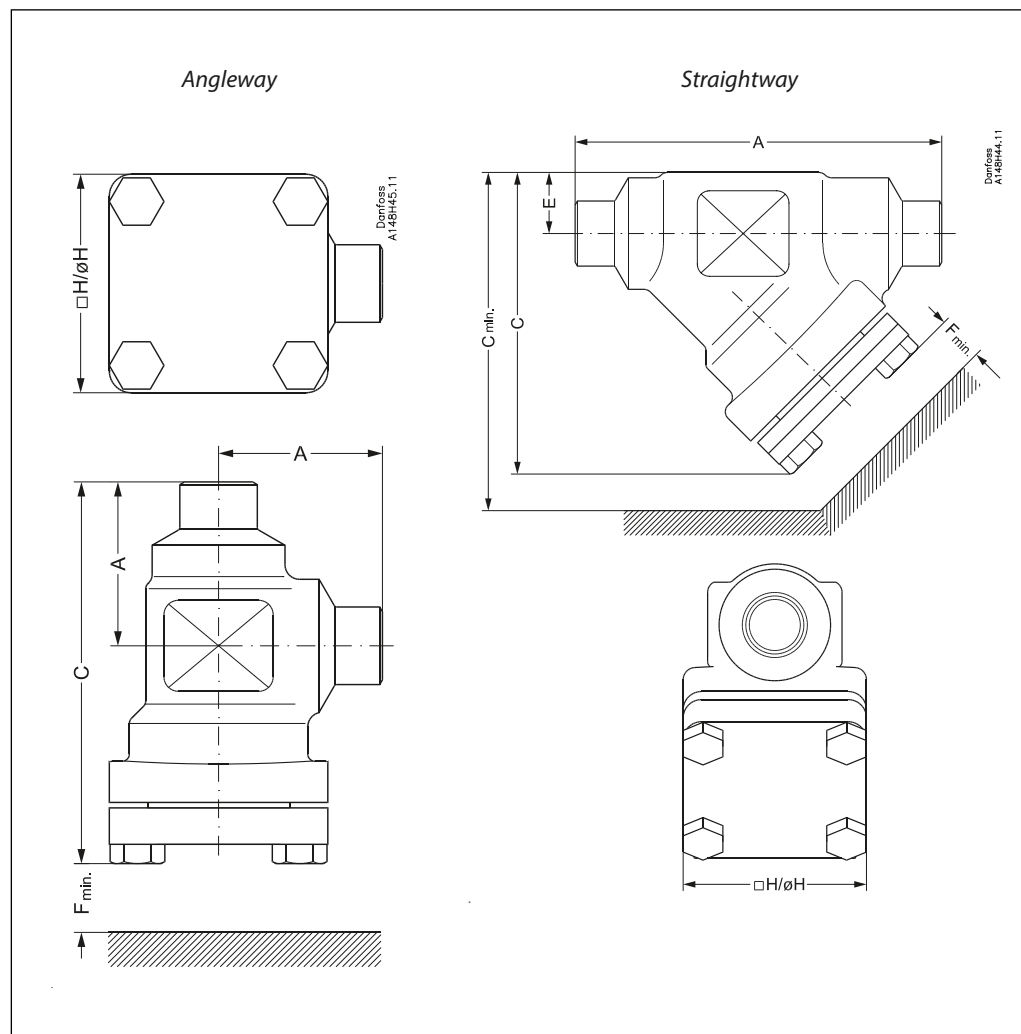

Angleway

Strainer size		A	C	H	F _{min.}	Weight
FIA SS 15 – 20	mm	45	105	60	68	1.1 kg
(1/2" – 3/4")	in.	1.77	4.13	2.36	2.68	2.4 lbs
FIA SS 25 – 40	mm	55	132	70	95	1.7 kg
(1" – 1 1/2")	in.	2.17	5.20	2.76	3.74	3.7 lbs
FIA SS 50	mm	60	132	77	92	2.8 kg
(2")	in.	2.36	5.20	3.03	3.62	6.2 lbs
FIA SS 65	mm	70	152	90	107	3.8 kg
(2 1/2")	in.	2.76	5.98	3.54	4.21	8.4 lbs

Straightway

Valve size		A	C	C _{min.}	H	E	F _{min.}	Weight
FIA SS 15 – 20	mm	120	99	133	60	20	68	1.4 kg
(1/2" – 3/4")	in.	4.72	3.90	5.24	2.36	0.79	2.68	3.1 lbs
FIA SS 25-40	mm	155	129	177	70	26	95	2.4 kg
(1" – 1 1/2")	in.	6.10	5.08	6.97	2.76	1.02	3.74	5.3 lbs
FIA SS 50	mm	148	138	184	77	32	92	3.5 kg
(2")	in.	5.83	5.43	7.24	3.03	1.26	3.62	7.7 lbs
FIA SS 65	mm	176	165	219	90	40	107	5.3 kg
(2 1/2")	in.	6.93	6.50	8.62	3.54	1.57	4.21	11.7 lbs

Data sheet | Stainless Steel Valves 15 (½ in.) - 125 (5 in.)
Ordering

The table below is used to identify the strainer required. Please note that you have to order **FIA SS strainer without element, a strainer element and accessories.**

Example:

FIA SS 50 D ANG + FIA-X 50 150µ Strainer Element + Filter Bag = **148H5757 + 148H3130 + 148H3150**

Size		Type	FIA SS Without Filter Element	Filter Element 100µ	Filter Element 150µ	Filter Element 250µ	Filter Element 500µ	Pleated filter element 150µ	Pleated filter element 250µ	Pleated filter element 500µ
mm	in.			150 mesh	100 mesh	72 mesh	38 mesh	100 mesh	72 mesh	38 mesh

Butt-weld DIN (EN 10220) - Angleway

Size (mm)	Size (in.)	Type	Code	148H3122	148H3124	148H3126	148H3128	148H3303	148H3363	
15	½	FIA SS 15 D ANG	148B5295							-
20	¾	FIA SS 20 D ANG	148B5383							
25	1	FIA SS 25 D ANG	148B5492							
32	1¼	FIA SS 32 D ANG	148B5587	148H3123	148H3125	148H3127	148H3129	148H3304	148H3269	-
40	1½	FIA SS 40 D ANG	148B5666							
50	2	FIA SS 50 D ANG	148B5757	148H3157	148H3130	148H3138	148H3144	148H3179	148H3184	148H3189
65	2½	FIA SS 65 D ANG	148B5851	-	148H3131	148H3139	148H3145	148H3180	148H3185	148H3190

Butt-weld ANSI (B 36.19M SCHEDULE 10) - Angleway

Size (mm)	Size (in.)	Type	Code		148H3131	148H3139	148H3145	148H3180	148H3185	148H3190
65	2½	FIA SS 65 A10 ANG	148B6498	-						

Butt-weld DIN (EN 10220) - Straightway

Size (mm)	Size (in.)	Type	Code	148H3122	148H3124	148H3126	148H3128	148H3303	148H3363	
15	½	FIA SS 15 D STR	148B5296							-
20	¾	FIA SS 20 D STR	148B5384							
25	1	FIA SS 25 D STR	148B5493							
32	1¼	FIA SS 32 D STR	148B5588	148H3123	148H3125	148H3127	148H3129	148H3304	148H3269	-
40	1½	FIA SS 40 D STR	148B5667							
50	2	FIA SS 50 D STR	148B5758	148H3157	148H3130	148H3138	148H3144	148H3179	148H3184	148H3189
65	2½	FIA SS 65 D STR	148B5852	-	148H3131	148H3139	148H3145	148H3180	148H3185	148H3190

Butt-weld ANSI (B 36.19M SCHEDULE 40) - Straightway

Size (mm)	Size (in.)	Type	Code	148H3122	148H3124	148H3126	148H3128	148H3303	148H3363	
15	½	FIA SS 15 A40 STR	148B6493							-
20	¾	FIA SS 20 A40 STR	148B6494							
25	1	FIA SS 25 A40 STR	148B6495							
32	1¼	FIA SS 32 A40 STR	148B6496	148H3123	148H3125	148H3127	148H3129	148H3304	148H3269	-
40	1½	FIA SS 40 A40 STR	148B6497							

Butt-weld ANSI (B 36.19M SCHEDULE 10) - Straightway

Size (mm)	Size (in.)	Type	Code	148H3157	148H3130	148H3138	148H3144	148H3179	148H3184	148H3189
50	2	FIA SS 50 A10 STR	148B5758							
65	2½	FIA SS 65 A10 STR	148B6499	-	148H3131	148H3139	148H3145	148H3180	148H3185	148H3190

- D = Butt-weld DIN
- A = Butt-weld ANSI
- ANG = Angleway
- STR = Straightway

Accessories

Part	Accessory for	Code number
Filter element µ150 with removable element µ50 for the first start up	FIA SS 15 – 20	148H3301
	FIA SS 25 – 40	148H3302
Part	Accessory for	Code number
Filter bag	FIA SS 50	148H3150
	FIA SS 65	148H3151
Part	Accessory for	Code number
Blind nut with gasket	FIA SS 50 – 65	148H3450

**Pressure regulating valves
OFV-SS**

OFV-SS are angle-way over flow valves, which have adjustable opening pressure and cover the differential pressure range (ΔP): 2 – 8 bar / 29 – 116 psi. The valve can be closed manually, e.g. during plant service and have backseating, enabling the spindle seal to be replaced with the valve still under pressure.

The valves are especially designed to prevent fluttering due to low velocity and/or low density. In consequence it is possible to apply the valves with wide fluctuations in capacity demands, i.e. from maximum performance to part load. A flexible O-ring provides perfect sealing over the seat.



**Features
OFV-SS**

- Applicable to HCFC, HFC, R717(Ammonia) and R744 (CO₂).
- Full temperature range packing gland -50 – 150 °C / -58 – 302 °F
- Maximum operating pressure 52 bar / 754 psi g
- Three functions in one valve. The OFV valve combines the functions of an overflow valve, a check valve and a stop valve
- Low temperature stainless steel housing and bonnet
- Low temperature packing gland -60 – 150 °C / -76 – 302 °F
- Classification: DNV, CRN, BV, EAC etc. To get an updated list of certification on the products please contact your local Danfoss Sales Company.

Technical data

- Refrigerants Applicable to HCFC, HFC, R717(Ammonia) and R744 (CO₂). Flammable hydrocarbons are not recommended. For further information please contact your local Danfoss Sales Company.
- Temperature range -60 – 150 °C / -76 – 302 °F
- Pressure range Maximum operating pressure: 52 bar / 754 psi g
- Set pressure (Δp): 2 – 8 bar / 29 – 116 psi.

Design

Connections

Available with the following connections:

- Welding DIN (EN 10220)
- Welding ANSI (B 36.19M)

Packing gland OFV-SS

The stainless steel packing gland comprises a spring loaded seal packing gland which ensures a perfect tightness in the range:

-60 – 150 °C / -76 – 302 °F.

The packing glands are equipped with a scraper ring to prevent penetration of dirt and ice into the packing gland.

Pressure Equipment Directive (PED)

OFV valves are approved and CE-marked in accordance with the Pressure Equipment Directive - 97/23/EC.

For further details / restrictions - see Installation Instruction

Installation

The valve is designed to resist very high internal pressure, but as to the pipe system in general, hydraulic pressure caused by thermal expansions in entrapped refrigerants should be avoided. For further information please see OFV installation instruction.

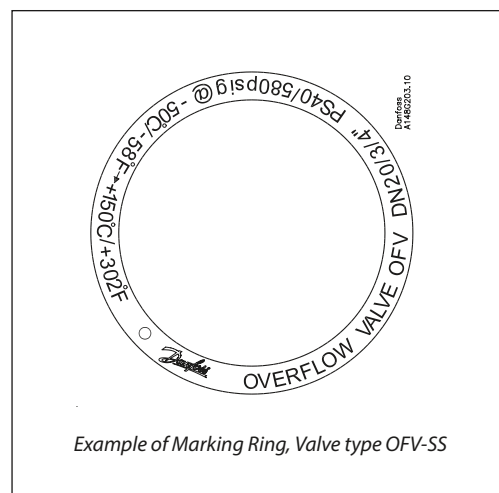

Example of Marking Ring, Valve type OFV-SS



	OFV-SS
Nominal bore	DN≤ 25 mm (1 in.)
Classified for	Fluid group I
Category	Article 3, paragraph 3

Connections

DIN

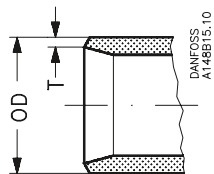

ANSI

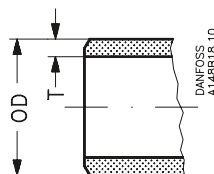

Size mm	Size in.	OD mm	T mm	OD in.	T in.
---------	----------	-------	------	--------	-------

Butt-weld DIN (EN 10220)

20	¾	26.9	2.3	1.059	0.091
25	1	33.7	2.6	1.327	0.103

Butt-weld ANSI (B 36.19M)

20	¾	26.9	2.9	1.06	0.11
25	1	33.7	3.5	1.33	0.14

Material specification

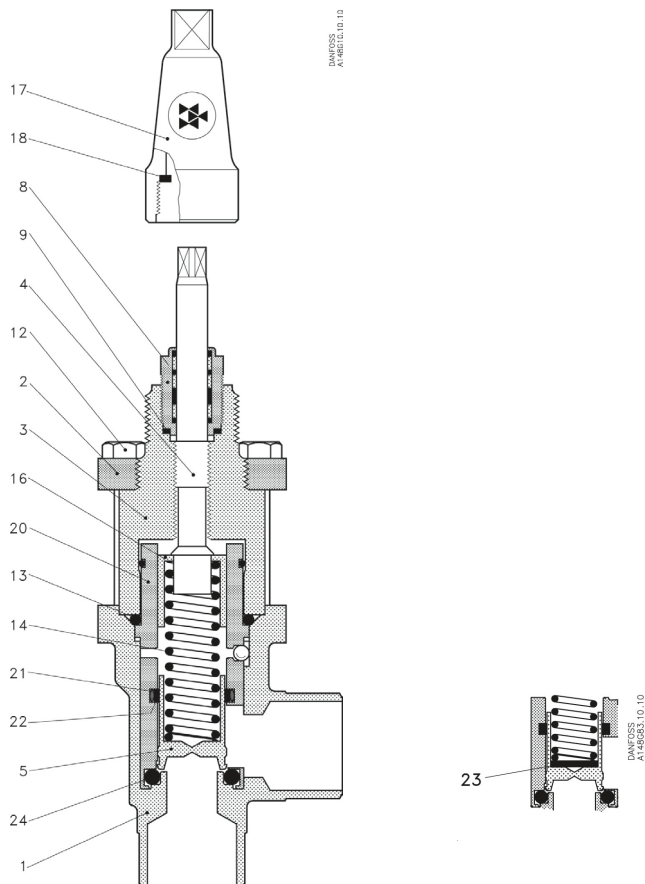

OFV-SS 20 - 25 (¾ - 1")

No.	Part	Material	DIN/EN	ISO	ASTM
1	Housing	Stainless steel	X5CrNi18-10 EN10088		AISI 304
2	Bonnet, Flange	Stainless steel	X5CrNi18-10 EN10088		AISI 304
3	Bonnet, Insert	Stainless steel			
4	Spindle	Stainless steel	X8CrNiS18-9 DIN 17440	Type 17, 683/13	AISI 303
5	Cone	Steel	9SMn28	Type 2	1213
8	Packing gland	Stainless steel			
9	Packing washer	Non asbestos			
12	Bolts	Stainless steel	A2-70	A2-70	Type 308
13	O-ring	Cloroprene (Neoprene)			
14	Spring	Steel			
16	Spring washer	Steel	Steel		
17	Spindle seal cap	Aluminium			
18	Seal cap gasket	Nylon			
20	Guide piece	Steel			
21	O-ring	Cloroprene (Neoprene)			
22	Sealing ring	PTFE (Teflon)			
23	Distance piece	Steel			
24	O-ring	Cloroprene (Neoprene)			

Dimensions and weights

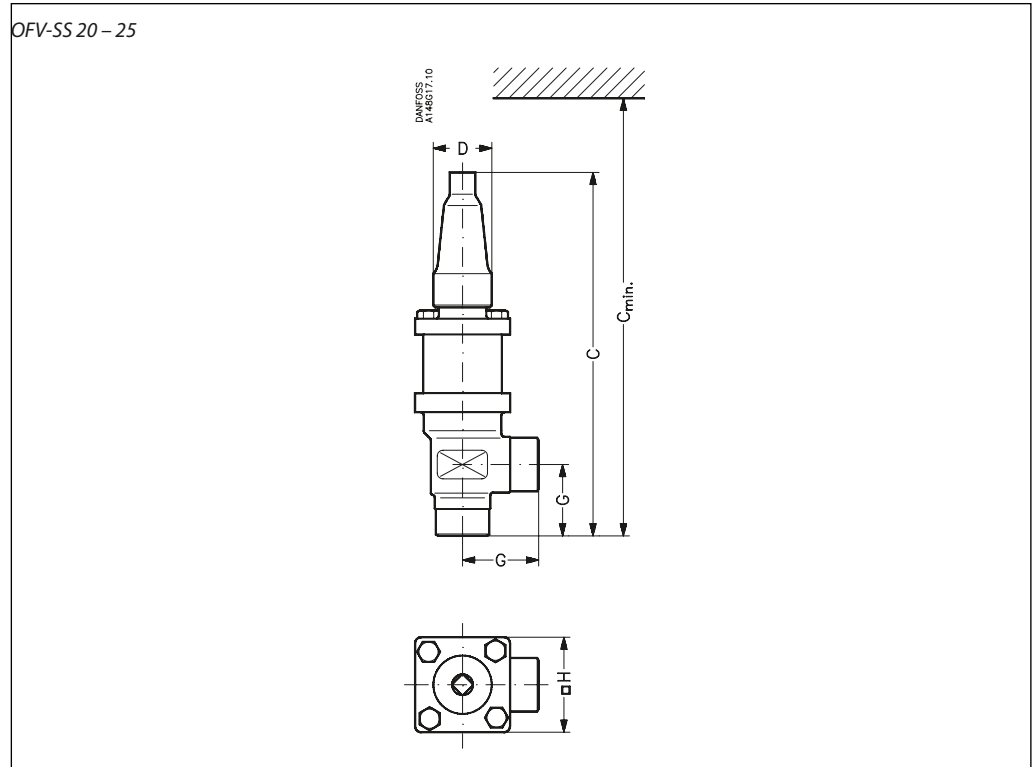

Valve size		G	C	C _{min}	∅D	□H	Weight
OFV 20 - 25							
OFV 20 (¾ in.)	mm in.	45 1.77	230 9.1	290 11.4	38 1.5	60 2.4	2.0 kg
OFV 25 (1 in.)	mm in.	45 1.77	230 9.1	290 11.4	38 1.5	60 2.4	2.0 kg

Specified weights are approximate values only.

Ordering
How to order

The table below is used to identify the valve required.

Please note that the type codes only serve to identify the valves, some of which may not form part of the standard product range.

For further information please contact your local Danfoss Sales Company.

Type codes

Valve type	OFV-SS	Over Flow Valve
Nominal size in mm	20 25	DN 20 DN 25
Connections	D A	Butt-weld connection: DIN EN 10220 Butt-weld connection: ANSI B 36.19M
Valve housing	ANG	Angle flow

Important!

Where products need to be certified according to specific certification societies or where higher pressures are required, the relevant information should be included at the time of order.

Opening differential pressure

2 – 8 bar / 29 – 116 psi:

Size		Type	Code No.
mm	in		
20	¾	OFV-SS 20 D ANG OVER FLOW VALVE 52BAR	148G3194
25	1	OFV-SS 25 D ANG OVER FLOW VALVE 52BAR	148G3195
25	1	OFV-SS 25 A ANG OVER FLOW VALVE 52BAR	148G3843

**Gauge valve
SNV-SS**

SNV-SS valves are designed to meet all industrial refrigeration application requirements.

Designed as service valves they provide favourable flow characteristics.



**Features
SNV-SS**

- Applicable to HCFC, non flammable HFC, R717 (Ammonia) and R744 (CO₂).
- Suitable for "heavy duty" industrial applications having a very sturdy and safe design including high pressures and wide temperature range.
- SNV-SS valves have backseating (metal to metal).
- Compact and light valve for easy handling and installation
- No special flow direction required.
- Provide high flow characteristics.
- Each valve type is clearly marked with type and size.
- Housing and bonnet material is (stainless steel according to requirements of the Pressure Equipment Directive and other international classification authorities.
- Valve safety is enhanced with the spindle being secured such that it cannot be unscrewed.
- Max. operating pressure: 52 bar g / 754 psig
Valves for higher operating pressure available on request
- Full temperature range: -60 – 150 °C / -76 – 302 °F
- Classification: DNV, CRN, BV, EAC etc.
To get an updated list of certification on the products please contact your local Danfoss Sales Company.

Technical data

- *Refrigerants*
Applicable to HCFC, non flammable HFC, R717 (Ammonia) and R744 (CO₂). For further information please see installation instruction for SNV-SS.
 - *Temperature range*
-60 – 150 °C / -76 – 302 °F.
 - *Maximum working pressure*
The valve is designed for: Maximum operating pressure of 52 bar g / 754 psig.
Valves for higher operating pressure available on request.
- For further information please contact your local Danfoss Sales Company.

Design

Connections
Available with the following connections:

- G

Housing
Made of stainless steel, approved for low temperature operations.

Spindle
Equipped with stainless steel spindle, which is ideal for O-ring sealing.

Installation
No special flow direction is required. The valve is designed to withstand high internal pressures. However, the piping system in general should be designed to avoid liquid traps and reduce the risk of hydraulic pressure caused by thermal expansion. For further information refer to installation instruction for SNV-SS.

Connections

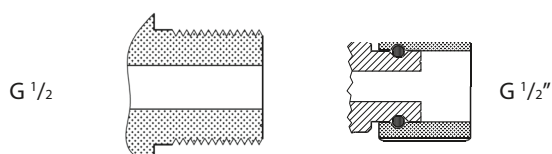

Material specification

SNV-SS (extended branch)

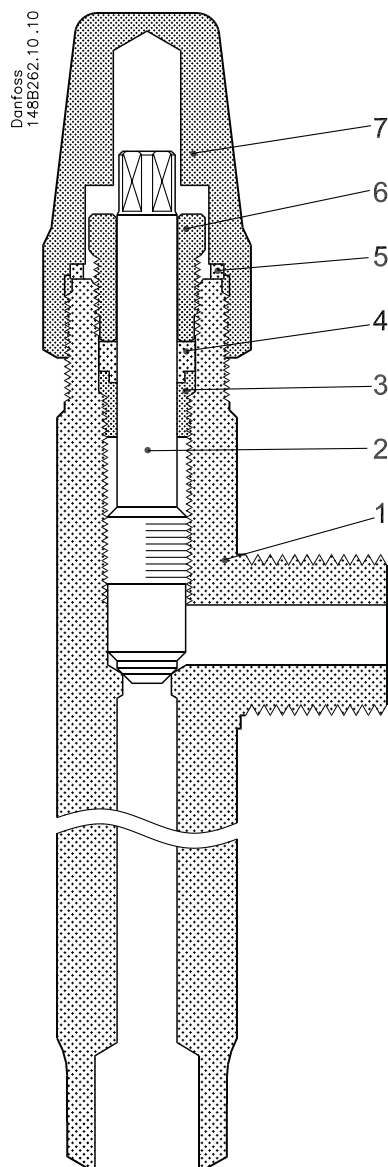

No.	Part	Material	EN	JIS	ASTM
1	Housing	Stainless steel (SNV-SS)	X5CrNi18-10, 10088		AISI 304
2	Spindle	Stainless steel	X8CrNiS 18-9 EN 10088' DIN 17440 (SNV-SS only)	SUS 303	AISI 303
3	Locking ring	Steel			
4	Sealing ring	Teflon			
5	Seal cap gasket	Nylon			
6	Gland nut	Steel			
7	Seal cap	Steel			

Dimensions and weights

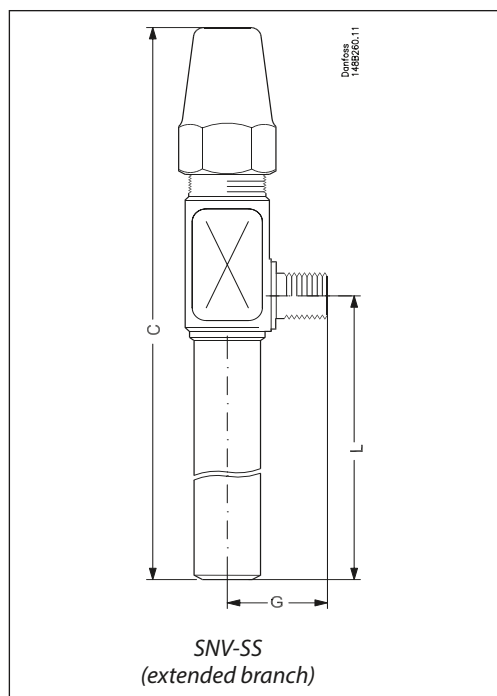

Type		C	G	L	Weight
SNV-SS	mm	131	32	50	0.60 kg
	in.	5.16	1.26	1.97	1.32 lb
SNV-SS Ext.branch	mm	231	32	150	0.60 kg
	in.	9.09	1.26	5.91	1.32 lb

Specified weights are approximate values only.

Ordering

SNV-SS Angle flow

Size		Type designation	Code number
G ½	W½L50	SNV-SS G1/2-W1/2 L50	148B4265
G ½	W½L150	SNV-SS G1/2-W1/2 L150	148B4266
G ½	W½L50	SNV-SS G1/2-W1/2 L50 - 65 bar	148B4581
G ½	W½L150	SNV-SS G1/2-W1/2 L150 - 65 bar	148B4582
3/8 FTP	3/8 MPT	SNV-SS 3/8 FTP-3/8 MPT	148B3750
G ½	-	SNV-SS G1/2 Manometer	148B6545
G ½	-	Blind nut SS incl. gasket	148B4317

**Solenoid valves
EVR3 and EVRST**

EVR3 and EVRST are valves made of stainless steel.

EVR3 is direct operated.
EVR3 10, 15 and 20 are servo operated.
EVRST 10,15 and 20 are forced servo operated valves used in liquid, suction, hot gas and oil return lines with ammonia or fluorinated refrigerants.

EVR3 and EVRST are designed for keeping open at a pressure drop of 0 bar.

EVR3/EVRST 10, 15 and 20 are equipped with spindle for manual opening.

EVR3 and EVRST are supplied as components, i.e. valve body and coil must be separately ordered.



**Features
EVR3 and EVRST**

- Stainless steel valve body and connections
- Max. working pressure 50 barg
- Applicable to HCFC, HFC, R717 (Ammonia) and R744 (CO₂).
- MOPD up to 38 bar with 20 watt a.c. coil
- Wide choice of a.c. and d.c. coils
- Designed for temperatures of media up to 105 °C
- Manual stem on EVR3 and EVRST 10, EVRST 15 and EVRST 20
- Classification: DNV, CRN, BV, EAC etc. To get an updated list of certification on the products please contact your local Danfoss Sales Company.

Technical data

Refrigerants
Applicable to HCFC, HFC, R717 (Ammonia) and R744 (CO₂).

Temperature of medium
-40 – 105 °C for 10 or 12 watt coil. Max. 130 °C during defrosting.
-40 – 80 °C for 20 watt coil.

Ambient temperature and enclosure for coil: See "Coils for solenoid valves", lit.no. DKRCC.PD.B50.A

Type	Opening differential pressure Δp bar					k _v value ²⁾ m ³ /h	Max. working pressure Ps
	Min.	Max. (MOPD) liquid ¹⁾					
		10 W a.c.	12 W a.c.	20 W a.c.	20 W d.c.		
EVR3	0.0	21	25	38	14	0.23	50 barg
EVR3 10	0.05	21	25	38	18	1.5	
EVRST 10	0.0	14	21	38	16	1.5	
EVR3 15	0.05	21	25	38	18	2.7	
EVRST 15	0.0	14	21	38	18	2.7	
EVR3 20	0.05	21	25	38	13	4.5	
EVRST 20	0.0	14	21	38	13	4.5	

¹⁾ MOPD for media in gas form is approx. 1 bar greater.
²⁾ The k_v value is the water flow in m³/h at a pressure drop in the valve of 1 bar, ρ = 1000 kg/m³.

Technical data
(Continued)

Type	Rated capacity ¹⁾ kW														
	Liquid					Suction vapour					Hot gas				
	R717	R22	R134a	R404A	R410A	R717	R22	R134a	R404A	R410A	R717	R22	R134a	R404A	R410A
EVRS 3	21.8	4.6	4.3	3.2	4.5						6.5	2.1	1.7	1.7	2.3
EVRS/EVRST 10	142.0	30.2	27.8	21.1	29.7	9.0	3.4	2.5	3.1	4.3	42.6	13.9	11.0	11.3	14.9
EVRS/EVRST 15	256.0	54.4	50.1	38.0	53.5	16.1	6.2	4.4	5.5	7.7	76.7	24.9	19.8	20.3	26.7
EVRS/EVRST 20	426.0	90.6	83.5	63.3	89.1	26.9	10.3	7.3	9.2	12.0	128.0	41.5	32.9	33.9	44.5

¹⁾ Rated liquid and suction vapour capacity is based on evaporating temperature $t_e = -10^\circ\text{C}$, liquid temperature ahead of valve $t_l = 25^\circ\text{C}$, and pressure drop across valve $\Delta p = 0.15$ bar.

Rated hot gas capacity is based on condensing temperature $t_c = 40^\circ\text{C}$, pressure drop across valve $\Delta p = 0.8$ bar, hot gas temperature $t_h = 60^\circ\text{C}$, and subcooling of refrigerant $\Delta t_{\text{sub}} = 4$ K.

Type	R 744 Rated capacity kW ²⁾	
	Liquid	Suction
EVRS 3	6.65	-
EVRS / EVRST 10	43.3	6.9
EVRS / EVRST 15	78.0	12.4
EVRS / EVRST 20	130.0	20.7

²⁾ Rated liquid and suction vapour capacity is based on evaporating temperature $t_e = -40^\circ\text{C}$, liquid temperature ahead of the valve $t_l = -8^\circ\text{C}$ and pressure drop across the valve $\Delta p = 0.15$ bar

For other condition please refer to DIR-Calc or contact your local Danfoss office.

Design / Function

- 4. Coil
- 16. Armature
- 18. Pilot valve plate
- 20. Earth terminal
- 24. Connection for flexible steel hose
- 28. Gasket
- 29. Pilot orifice
- 36. DIN plug
- 40. Terminal box
- 43. Valve cover
- 44. O-ring
- 45. Valve cover gasket
- 49. Valve body
- 51. Cover
- 53. Manual operating spindle
- 73. Equalization hole
- 80. Diaphragm
- 82. Support washer
- 83. Valve seat
- 84. Main valve plate

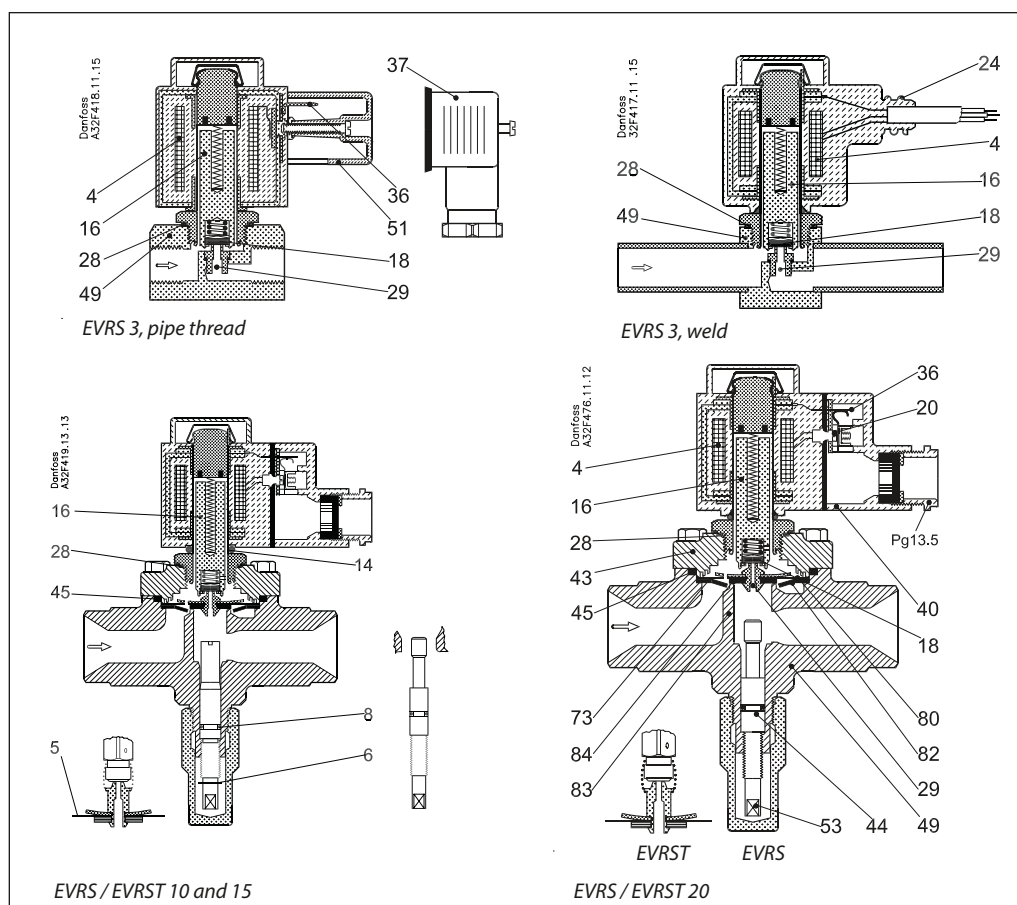

The solenoid valve design is based on three different principles:

1. Direct operation
2. Servo operation
3. Forced servo operation

1. Direct operation

EVRS3 is directly operated. The valve opens direct for full flow when the armature (16) moves up into the magnetic field of the coil. This means that the valve operates with a min. differential pressure of 0 bar. The valve plate (18) made of teflon and is fitted direct to the armature (16).

Inlet pressure acts from above on the armature and with it the valve plate. Thus, inlet pressure, spring force and the weight of the armature act to close the valve when the coil is currentless.

2. Servo operation

EVRS 10, 15 and 20 are servo operated with a "floating" diaphragm (80). The pilot orifice (29), which is of stainless steel, is placed in the centre of the diaphragm.

The teflon pilot valve plate (18) is fitted direct to the armature (16).

With the coil currentless, the main orifice and pilot orifice are closed.

The pilot orifice and main orifice are held closed by the weight of the armature, the armature spring force and the differential pressure between inlet and outlet sides.

When current is applied to the coil the armature is drawn up into the magnetic field and opens the pilot orifice. This relieves the pressure above the diaphragm because the space above the diaphragm becomes connected to the outlet side of the valve. The differential pressure between inlet and outlet sides then presses the diaphragm away from the main orifice which opens to full flow.

Thus a certain minimum differential pressure is necessary to open the valve and keep it open. For EVRS 10, 15 and 20 valves this differential pressure is 0.05 bar.

When current is switched off, the pilot orifice closes. Then the pressure above the diaphragm rises, via the equalization holes (73) in the diaphragm, to the inlet pressure and causes the diaphragm to close the main orifice.

3. Forced servo operation

EVRST 10, 15 and 20 are forced servo operated solenoid valves.

Forced servo operation differs from servo operation in that in a forced servo operated valve the armature and the diaphragm are connected by a spring. Thus the armature helps to lift the diaphragm (80) and keep it lifted so that the pressure drop in the open valve is the least possible. These types of valves therefore require no differential pressure to keep them open.

Material specification

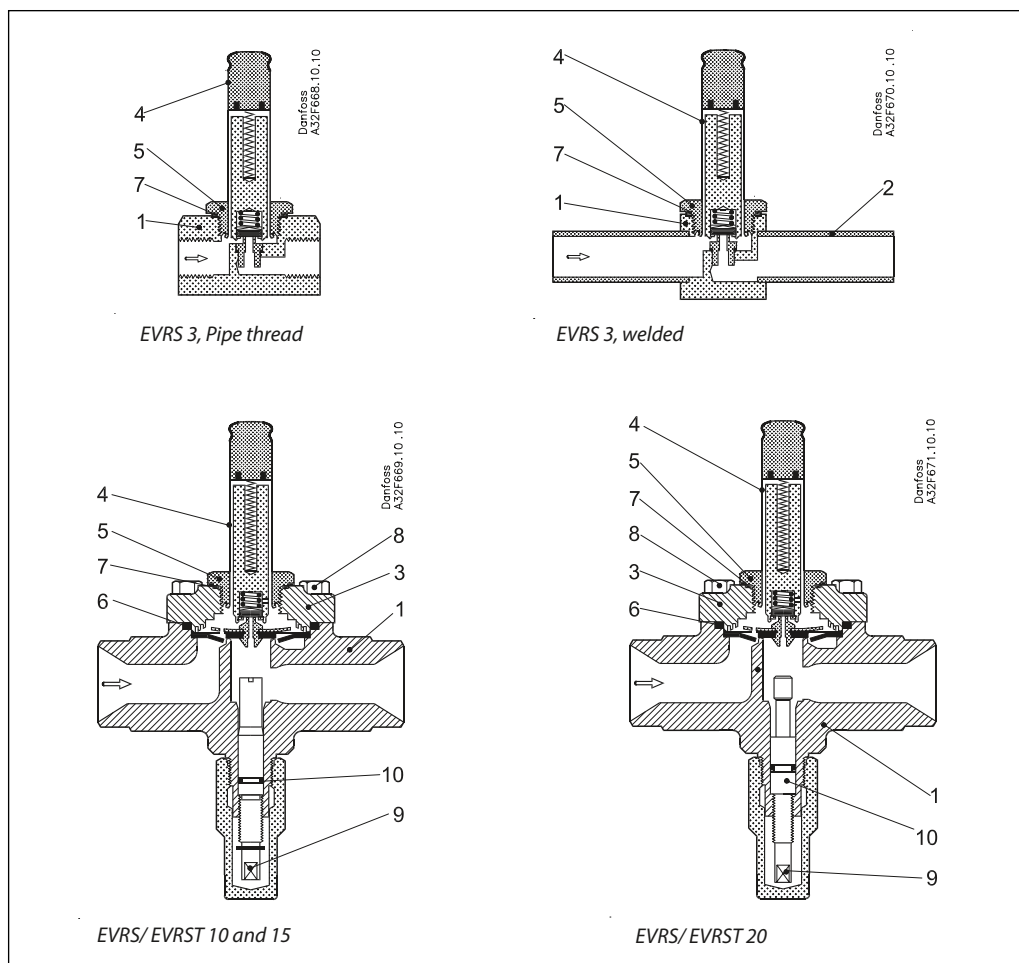

		Solenoid valves				Standard		
No.	Description	Type	Material	Analysis	Mat.no.	W.no.	DIN	EN
1	Valve housing	EVRS 3	Stainless steel	X8 CrNiS 18-9		1.4305		10088
		EVRS (T) 10/15/20	Stainless steel	X6 CrNi 18-9		1.4308	17455	
2	Welding tube	EVRS 3	Stainless steel	X2 CrNiMo 17-12-2		1.4404	17455	
3	Cover	EVRS (T) 10/15/20	Stainless steel	X6 CrNi 18-9		1.4308	17455	
4	Armature tube	EVRS(T) 3/10/15/20	Stainless steel	X2 CrNi 19-11		1.4306		10088
5	Armature tube nut	EVRS(T) 3/10/15/20	Stainless steel	X8 CrNi 19-11		1.4305		10088
6	Gasket	EVRS(T) 3/10/15/20	Rubber	Cr				
7	Gasket armature tube	EVRS(T) 10/15/20	Al gasket	Al 99.5		3.0255		10210
8	Screws	EVRS(T) 10/15/20	Stainless steel	A2-70			3506	
9	Spindle for man. oper.	EVRS(T) 10/15/20	Stainless steel	X8 CrNiS 18-9		1.4305		10088
10	Gasket	EVRS(T) 10/15/20	Rubber	Cr				

Dimensions and weights

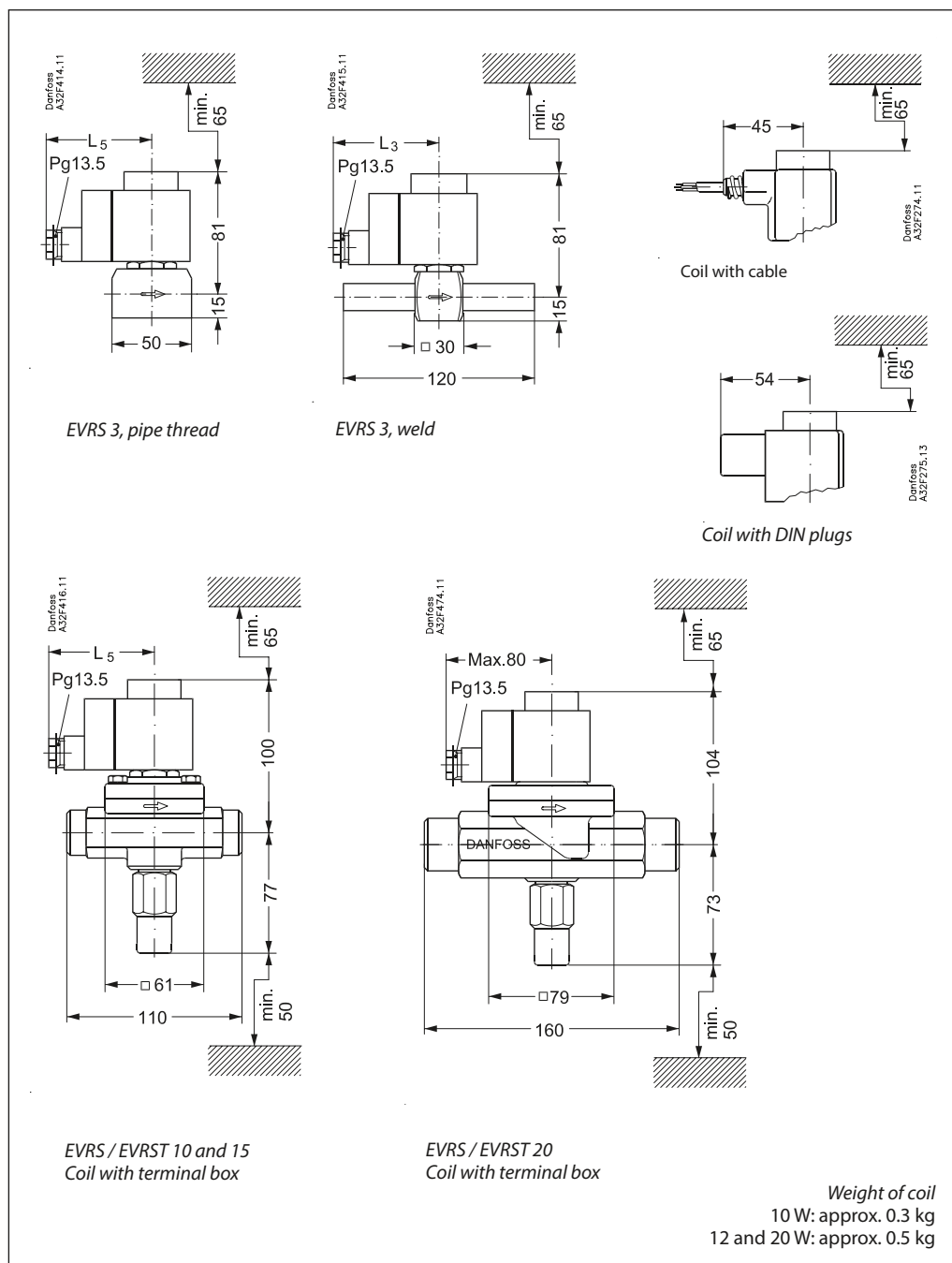

Type	L_5 max.		Weight with coil kg
	10 W mm	12 W 20 W mm	
EVRS 3, pipe thread	75	85	0.7
EVRS 3, weld	75	85	0.6
EVRS/EVRST 10	75	85	1.2
EVRS/EVRST 15	75	85	1.3
EVRS/EVRST 20	75	85	2.0

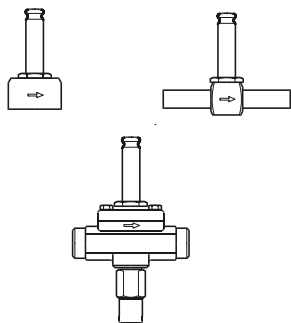
Ordering

Separate valve bodies

Type	Max. working pressure Ps barg	Connection		Code no.	
		Weld in.	Pipe thread ISO 228/1	With manual stem	Without manual stem
EVR3 3	50	3/8			032F3080
EVR3 3	50		G 1/4		032F3081
EVR3 10	50	1/2		032F3082	
EVRST 10	50	1/2		032F3083	
EVR3 15	50	3/4		032F3084	
EVRST 15	50	3/4		032F3085	
EVR3 20	50	1		032F5437	
EVRST 20	50	1		032F5438	

 Coils See "Coils for solenoid valves", lit.no. *DKRCC.PD.BS0.A*

