

## Data Sheet

Check and stop valve  
Type **SCA-X** and **CHV-X****With butt-weld connection F**

Designed to open at very low differential pressures



SCA-X are check valves with a built-in stop valve function. CHV-X are check valves only. SCA-X/ CHV-X are available in angleway versions. The valves are designed to open at very low differential pressures, allow favourable flow conditions and are easy to disassemble for inspection and service.

The SCA-X is equipped with vented cap and has internal backseating enabling the spindle seal to be replaced whilst the valve still under pressure. Laser cut V-ports provide excellent opening characteristics (SCA-X/CHV-X 50-125).

The valve cone has a built-in flexibility to ensure a precise and tight closing towards the valve seat. A well balanced dampening effect between the piston and the cylinder gives an optimal protection during low loads and against pulsations. A well balanced dampening effect between the piston and the cylinder gives an optimal protection during low loads and against pulsations.

### Features

- Modular Concept:
  - Each valve housing is available with butt-weld F connection and in several different sizes.
  - Possible to convert SCA-X or CHV-X to any other product in the Flexline™ SVL family (regulating valve, shut-off valve or strainer) just by replacing the complete top part.
- Fast and easy valve overhaul service. It is easy to replace the top part and no welding is needed.
- Designed to open at a very low differential pressure of 0.04 bar (0.58 psig).
- Designed with a built-in damping chamber preventing valve flutter in case of low refrigerant velocity and/or low density.
- Each valve is clearly marked with type, size and performance range.
- Easy to disassemble for inspection and service.
- Internal backseating enables replacement of the spindle seal whilst the valve is active, i.e. under pressure.
- Optimal flow characteristics ensuring quick opening to the fully open position.
- Protection against pulsation by built-in damping facility.
- Housing and bonnet material is low temperature steel according to requirements of the Pressure Equipment Directive and other international classification authorities.
- Equipped with Stainless steel bolts.
- Classification: DNV, CRN, BV, EAC etc. To get an updated list of certification on the products please contact your local Danfoss Sales Company.

## Applications

### **Application**

Below diagram shows the check & stop valve SCA-X in the discharge line of a screw compressor unit. The SCA-X valve in the discharge line prevents “back condensation” in the oil separator as well as pressure equalising through the compressor.

Compared to an ordinary stop and check valve arrangement the combined stop/check valve solution, as shown, is easier to install and has lower flow resistance. Installation of the SCA-X/CHV-X in the economizer line is not recommended.

**Figure 1: Flow diagram**

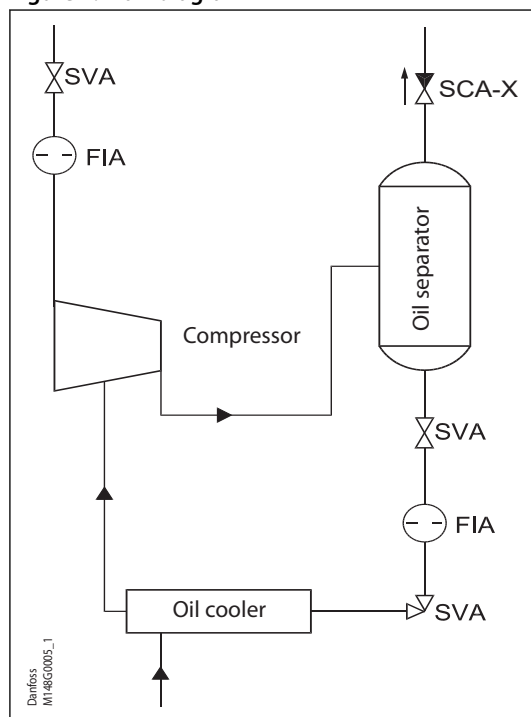

## Media

### **Refrigerants**

Applicable to HCFC, HFC, R717 (Ammonia) and R744 (CO<sub>2</sub>). For further information refer to the product instruction for SCA-X/CHV-X.

### **New refrigerants**

Danfoss products are continually evaluated for use with new refrigerants depending on market requirements.

When a refrigerant is approved for use by Danfoss, it is added to the relevant portfolio, and the R number of the refrigerant (e.g. R513A) will be added to the technical data of the code number. Therefore, products for specific refrigerants are best checked at [store.danfoss.com/en/](https://store.danfoss.com/en/), or by contacting your local Danfoss representative.

**Product specification**

**Pressure and temperature data**

Table 1: Pressure and temperature data

Features	Description
Temperature range	-60 °C /+150 °C (-76 °F/+302 °F).
Max. working pressure	52 bar (754 psi)

Figure 2: Pressure/Temperature range chart for SVL product range with butt-weld connection F

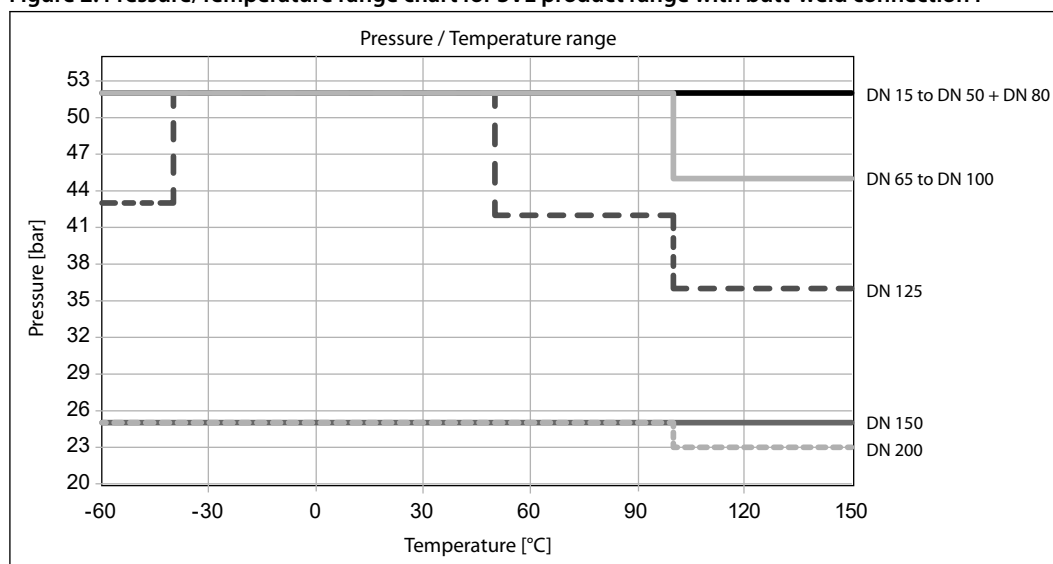

**For valve sizes DN 15 to DN 50 and DN 80:**

52 bar (754 psig) at -60 °C to +150 °C (-76 °F to +302 °F).

**For valve sizes DN 65 and DN100:**

52 bar (754 psig) at -60 °C to +100 °C (-76 °FF to +212 °F),  
45 bar (652 psig) at +100 °C to +150 °C (+212 °F to +302 °F).

**For valve size DN 125:**

52 bar (754 psig) at -40 °C to +50 °C (-40 °F to +122 °F)  
43 bar (623 psig) at -60 °C to -40 °C (- 76 °F to -40 °F),  
42 bar (609 psig) at +50 °C to +100 °C (+122 °F to +212 °F),  
36 bar (522 psig) at +100 °C to+150 °C (+212 °F to +302 °F).

**For valve size DN 150:**

25 bar (362 psig) at -60 °C to +150 °C (-76 °F to +302 °F).

**For valve size DN 200:**

25 bar (362 psig) at -60 °C to +100 °C (-76 °F to +212 °F),  
23 bar (333 psig) at +100 °C to +150 °C (+212 °F to +302 °F).

SVL housings with other connection types (DIN, ANSI, SOC and thread) are approved for a maximum working pressure of 52 bar (754 psig) at -60 °C to +150 °C (-76 °F to +302 °F) for all sizes.

The reduced pressure in some of the SVL housings with connection type F is caused by the welding onto stainless steel pipes with reduced pipe size.

## Check and stop valve, type SCA-X and CHV-X, With butt-weld connection F

Table 2: Pressure/Temperature range chart for SVL product range with butt-weld connection F

Size [DN]	SVA-S				SVA-L				SCA-X	CHV-X	FIA		REG-SA		REG-SB	
	ANG		STR		ANG		STR		ANG	ANG	ANG	STR	ANG	STR	ANG	STR
	H-WHEEL	CAP	H-WHEEL	CAP	H-WHEEL	CAP	H-WHEEL	CAP	CAP	CAP	CAP	CAP	CAP	CAP	CAP	CAP
15	X	X	X	X	X	X	X	X	X	X	X	X	X	X	X	X
20	X	X	X	X	X	X	X	X	X	X	X	X	X	X	X	X
25	X	X	X	X	X	X	X	X	X	X	X	X	X	X	X	X
32	X	X	X	X	X	X	X	X	X	X	X	X	X	X	X	X
40	X	X	X	X	X	X	X	X	X	X	X	X	X	X	X	X
50	X	X	X	X					X	X	X	X			X	
65	X	X	X	X					X	X	X	X			X	
80	X	X	X	X					X	X	X	X				
100	X	X	X	X					X	X	X	X				
125	X	X	X	X					X	X	X	X				
150	X	X	X	X							X	X				
200	X	X	X	X							X	X				

**X = Available**

### Connections

Figure 3: F connection

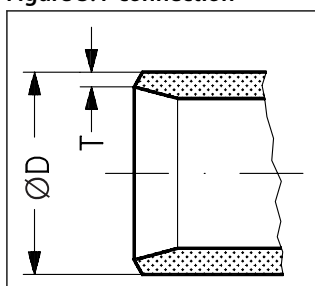

Size	Size	øD	T	øD	T	k <sub>v</sub> -angle	C <sub>v</sub> -angle
mm	in.	mm	mm	in.	in.	m <sup>3</sup> /h	US <sub>gal</sub> /min
15	½	21.3	2	0.839	0.079	8	9.3
20	¾	26.9	2	1.059	0.079	10	11.6
25	1	33.7	2	1.327	0.079	24	27.8
32	1¼	42.4	2	1.669	0.079	30	34.8
40	1½	48.3	2	1.902	0.079	30	34.8
50	2	60.3	2	2.37	0.079	45	53
65	2½	76.1	2	3	0.079	72	85
80	3	90.9	3	3.579	0.118	103	129
100	4	116.3	3	4.579	0.118	196	232
125	5	141.7	3	5.579	0.118	301	356

### Connections

Available with the following connections:

- Butt-weld connection "F" :
  - DN 15 to 65 size: 2 mm thick
  - DN 80 -125 size: 3 mm thick

### Design

#### Housing

The housing is made from special, cold resistant steel.

#### Valve cone

Valve cone with built in metallic stop - prevents damage to teflon ring in case of overtightening.

#### Damping chamber

## Check and stop valve, type SCA-X and CHV-X, With butt-weld connection F

The chamber is filled with refrigerants (gas or liquid), which provides a damping effect when the valve opens and closes.

### Spindle (SCA-X)

Made of polished stainless steel, which is ideal for O-ring sealing.

### Packing Gland (SCA-X)

The “full temperature range” packing gland is the standard for the entire SVL platform.

This ensures perfect tightness throughout the whole temperature range: -60/+150 °C (-76/+302 °F).

## Installation

Figure 4: Example of marking ring, CHV-X

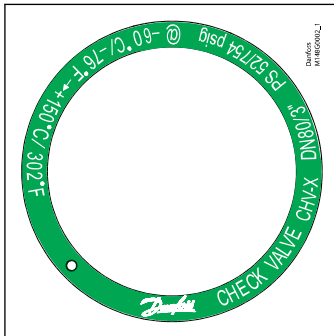

The valve must be mounted vertically with the cone downwards. The valve is designed to resist very high internal pressure. However, the piping system in general should be designed to avoid liquid traps and reduce the risk of hydraulic pressure caused by thermal expansion.

For further information refer to installation instructions for SCA-X/CHV-X. If cold refrigeration oil having low viscosity enters and settles in the damping chamber, problems with the check valve may arise. Consequently, it may be necessary to modify the valve for more viscous liquids by enlarging the hole to the damping chamber.

## Computation and selection

### Introduction

When dimensioning SCA-X/CHV-X, it is important to select a valve that is best suited to all operating conditions. Therefore, it is necessary to consider both the nominal and part load working conditions.

The SCA-X/CHV-X valve can be calculated in two ways:

- Using the tables below.
- Using DIRcalc version 1.14 or higher.

Table 3: Example

SI-Units	US-Units
Assumed working conditions: Maximum flow $V = 1000 \text{ m}^3/\text{h}$ Density $\rho = 3.0 \text{ kg}/\text{m}^3$ Minimum part load = 33%	Assumed working conditions: Maximum flow $V = 1160 \text{ gpm}$ Density $\rho = 0.187 \text{ lb}/\text{feet}^3$ Minimum part load = 33%
Used expressions: Recommended velocity - $C_{rec}$ [m/s] Minimum recommended velocity - $C_{min, rec}$ [m/s] Maximum velocity - $C_{max}$ [m/s] Part load velocity - $C_{part}$ [m/s]	Used expressions: Recommended velocity - $C_{rec}$ [ft/min] Minimum recommended velocity - $C_{min, rec}$ [ft/min] Maximum velocity - $C_{max}$ [ft/min] Part load velocity - $C_{part}$ [ft/min]
We know the density $\rho \approx 3.0 \text{ kg}/\text{m}^3$ , consequently $C_{rec}$ as well as $C_{min, rec}$ can be found in the figure below (standard valve).	We know the density $\rho \approx 0.187 \text{ lb}/\text{feet}^3$ , consequently $C_{rec}$ as well as $C_{min, rec}$ can be found in the figure (standard valve).
$C_{rec} \approx 14 \text{ m/s}$ $C_{min, rec} \approx 3 \text{ m/s}$	$C_{rec} \approx 2756 \text{ ft/min}$ $C_{min, rec} \approx 591 \text{ ft/min}$

Check and stop valve, type SCA-X and CHV-X, With butt-weld connection F

Figure 5: Computation and selection

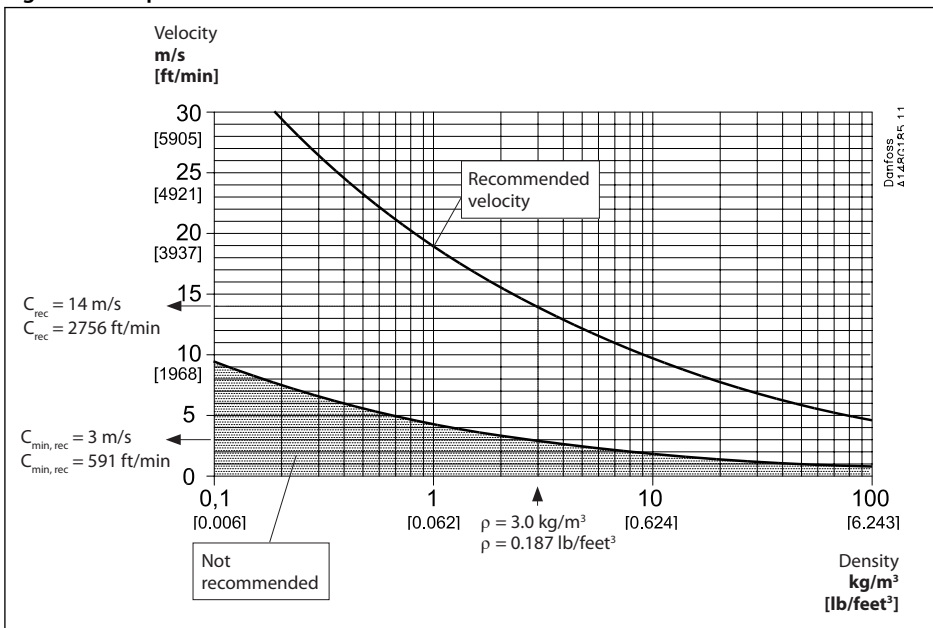

Knowing that  $V = 1000 \text{ m}^3/\text{h}$  (1160 gpm) fig. 2 gives the following choices:

For SCA-X/CHV-X in size DN 100 the maximum velocity  $C_{\text{max}} \approx 31 \text{ m/s}$  (6100 ft/min)

For SCA-X/CHV-X in size DN 125 the maximum velocity  $C_{\text{max}} \approx 20 \text{ m/s}$  (3900 ft/min)

In conclusion SCA-X in size DN 125 is selected because  $C_{\text{max}} \approx 20 \text{ m/s}$  (3900 ft/min) comes nearest to the recommended velocity  $C_{\text{rec}} \approx 14 \text{ m/s}$  (2756 ft/min) and at the same time part load conditions fulfil the requirements, as described:

We know that  $C_{\text{max}} \approx 20 \text{ m/s}$  (3900 ft/min) and that minimum part load is 33%. It follows that  $C_{\text{part}} \approx 6.5 \text{ m/s}$  (1290 ft/min). Thus,  $C_{\text{part}}$  (6.5 m/s) >  $C_{\text{min, rec}}$  (3.0 m/s) and the selected SCA-X model DN125 is the perfect choice.

If the valve in question (for instance under part load conditions) provides a velocity less than  $C_{\text{min, rec}}$  the valve might start hammering and become noisy. As a result the valve may wear prematurely.

Figure 6: DN 15 - 40

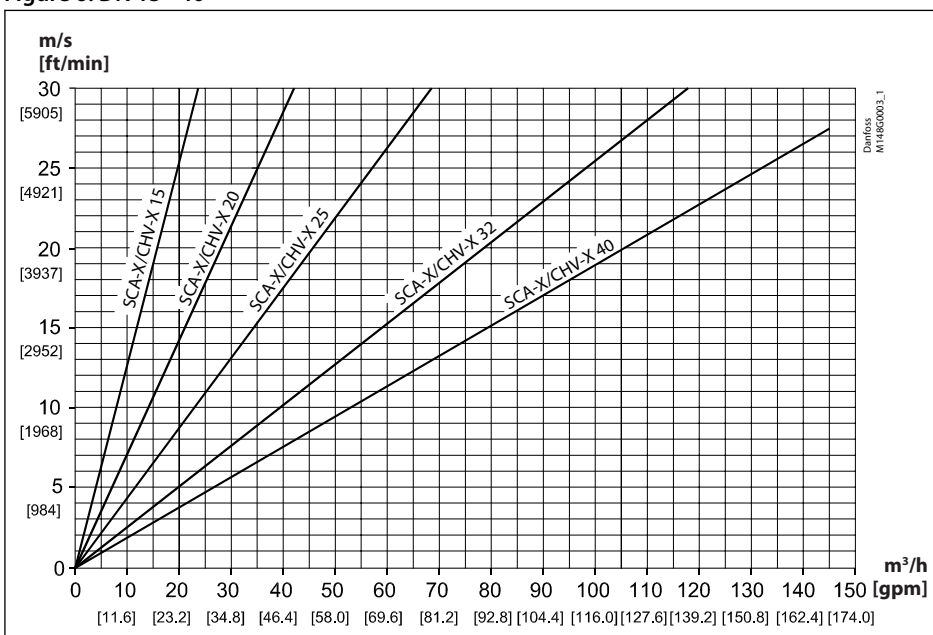



Check and stop valve, type SCA-X and CHV-X, With butt-weld connection F

Figure 7: DN 50 - 125

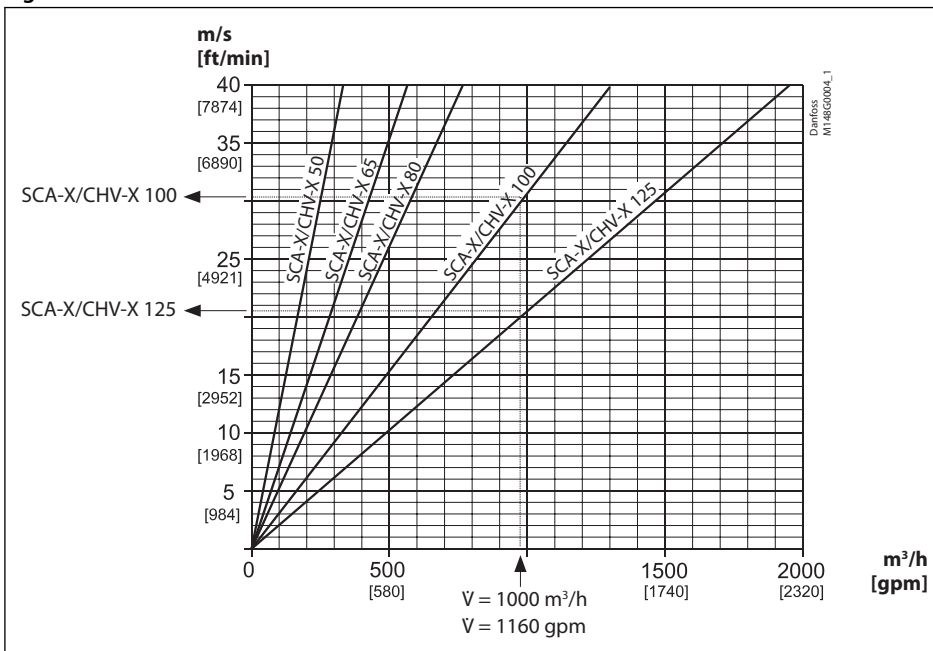

**Material specification**

Table 4: SCA-X 15 - 40 and CHV-X 15 - 40

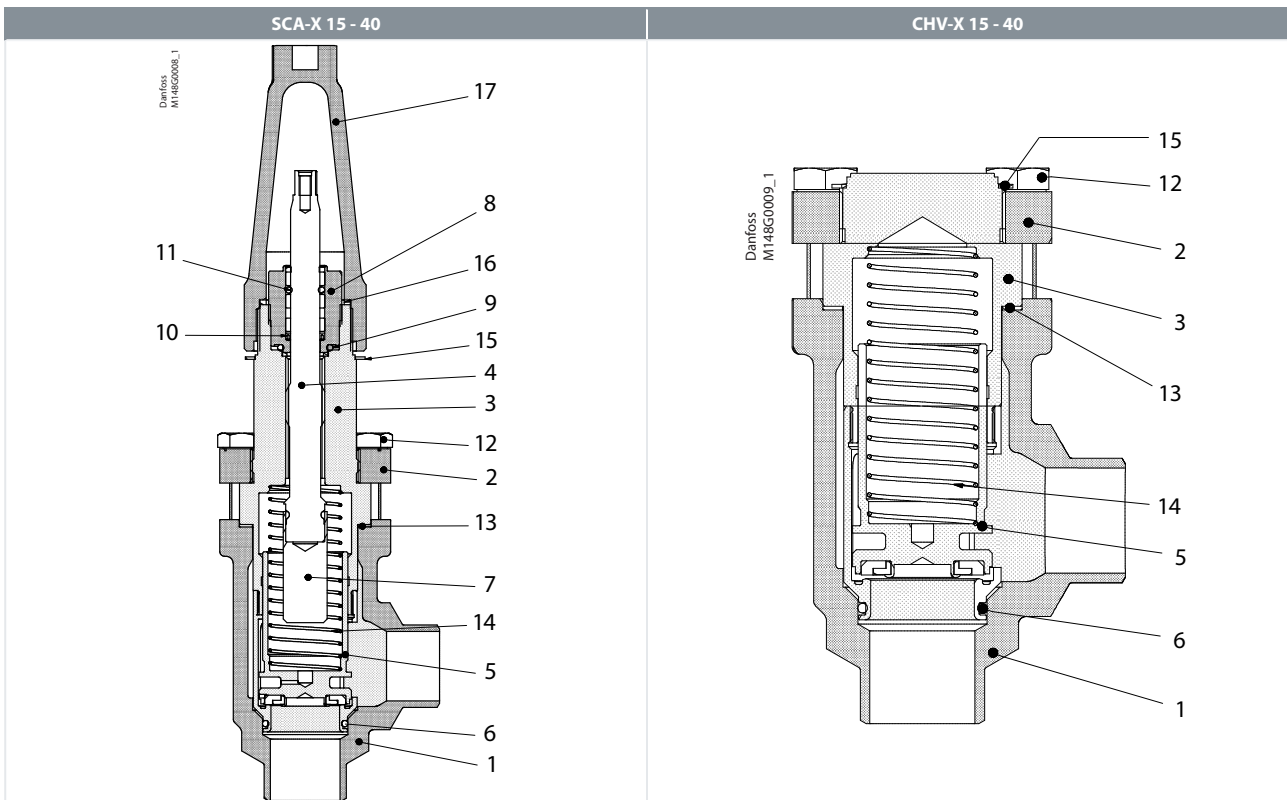

Table 5: Material specification

No.	Part	Material	DIN/EN	ISO	ASTM
1	Housing	Steel	G20Mn5QT, 10213-3		LCC, A352
			P285QH+QT, 10222-4		LF2, A350
2	Bonnet, Flange	Steel	P275NL1 EN10028-3	Type 2 R 683/9	LF2, A350
3	Bonnet, Insert	Steel	11SMn30 10087		AISI 1213
4	Spindle	Stainless steel	X8CrNiS18-9, EN 10088-3	Type 17 683/13	AISI 303

## Check and stop valve, type SCA-X and CHV-X, With butt-weld connection F

No.	Part	Material	DIN/EN	ISO	ASTM
5	Cone	Steel			
		Teflon (PTFE)			
6	O-ring	Chloroprene (Neoprene)			
7	Spindle extension	Steel			
8	Packing gland O-rings	Stainless steel	X8CrNiS18-9 10088	Type 17 683/13	AISI 303
		Chloroprene (Neoprene)			
9	Packing washer	Aluminium			
10	Spring loaded seal	Teflon (PTFE)			
11	O-ring	Chloroprene (Neoprene)			
12	Bolts	Stainless steel	A2-70	A2-70	Type 308
13	Gasket	Fiber, non-asbestos			
14	Spring	Steel			
15	Identification ring	Stainless steel			
16	Seal cap gasket	Nylon			
17	Spindle seal cap	Aluminium			

**Table 6: SCA-X 50 - 125 and CHV-X 50 - 125**

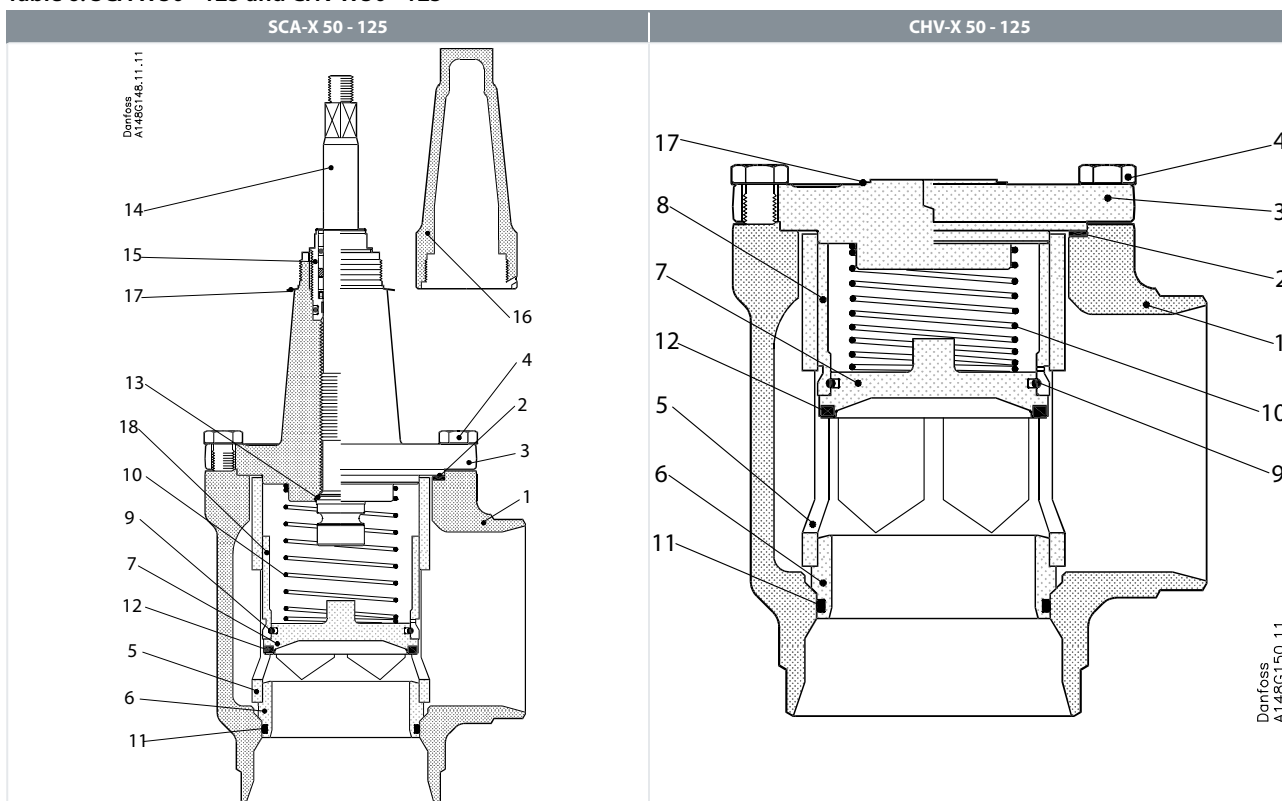

No.	Part	Material	DIN/EN	ISO	ASTM
1	Housing DN 50-65	Steel	G20Mn5QT, 10213-3		LCC, A352
			P285QH+QT, 10222-4		LF2, A350
	Housing DN 80-125	Steel	G20Mn5 QT SEW 685	LCC, A352	
2	Gasket	Fiber, Non-asbestos			
3	SCA-X: Valve bonnet CHV-X: End cover	Steel	P285 QH EN 10222-4		LF2, A350
			P275NL1 or 2 EN10028-3		A, A662
4	Bolts	Stainless steel	A2-70	A2-70	A-276
5	Tube	Steel			
6	Seat	Steel			
7	Valve plate	Steel			
8	Guide sleeve	Steel			
9	Spring ring	Steel			
10	Spring	Steel			
11	O-ring	Chloroprene (Neoprene)			

## Check and stop valve, type SCA-X and CHV-X, With butt-weld connection F

No.	Part	Material	DIN/EN	ISO	ASTM
12	Teflon ring	Teflon (PTFE)			
13	Soft back seal	Teflon (PTFE)			
14	Spindle DN 50-65	Stainless steel	X8CrNiS18-9 17440	Type 17 R 683/13	AISI 303
	Spindle DN 80-125	Stainless steel	X5CrNi1810 17440	Type 11 683/13	AISI 304 A-276
15	Packing gland	Stainless steel	X8CrNiS18-9, EN 10088-3,	Type 17 R 683/13	AISI 303
16	Spindle seal cap and gasket	Aluminium			
17	Marking label	Stainless steel			

## Dimensions and weights

Table 7: SCA-X/CHV-X 15 - 40 (½- 1½ in.)

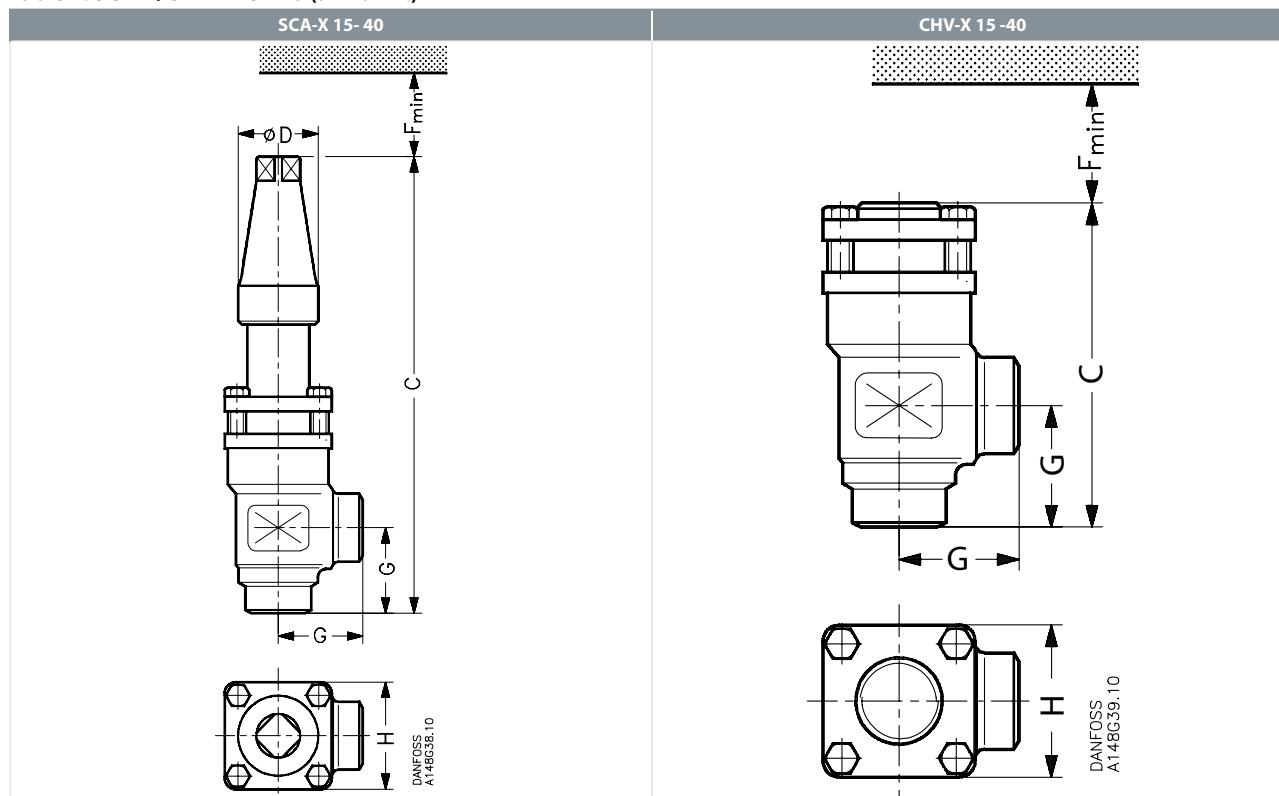

Table 8: SCA-X 15 - 40

Valve size		C	G	ØD	F <sub>min</sub>	H	Weight
SCA-X 15 (½ in.)	mm	212	45	38	60	60	1.6 kg
	in.	8.35	1.77	1.5	2.36	2.36	3.53 lb
SCA-X 20 (¾ in.)	mm	212	45	38	60	60	1.6 kg
	in.	8.35	1.77	1.5	2.36	2.36	3.53 lb
SCA-X 25 (1 in.)	mm	295	55	50	85	70	3.2 kg
	in.	11.61	2.17	1.97	3.35	2.76	7.05 lb
SCA-X 32 (1¼ in.)	mm	295	55	50	85	70	3.2 kg
	in.	11.61	2.17	1.97	3.35	2.76	7.05 lb
SCA-X 40 (1½ in.)	mm	295	55	50	85	70	3.2 kg
	in.	11.61	2.17	1.97	3.35	2.76	7.05 lb

Table 9: CHV-X 15 - 40

Valve size		C	G	F <sub>min</sub>	H	Weight
CHV-X 15 (½ in.)	mm	103	45	60	60	1.2 kg
	in.	4.06	1.77	2.36	2.36	2.65 lb
CHV-X 20 (¾ in.)	mm	103	45	60	60	1.2 kg
	in.	4.06	1.77	2.36	2.36	2.65 lb
CHV-X 25 (1 in.)	mm	143	55	85	70	2.3 kg
	in.	5.63	2.17	3.35	2.76	5.07 lb

## Check and stop valve, type SCA-X and CHV-X, With butt-weld connection F

Valve size		C	G	F <sub>min</sub>	H	Weight
CHV-X 32 (1¼ in.)	mm	143	55	85	70	2.3 kg
	in.	5.63	2.17	3.35	2.76	5.07 lb
CHV-X 40 (1½ in.)	mm	143	55	85	70	2.3 kg
	in.	5.63	2.17	3.35	2.76	5.07 lb

Specified weights are approximate values only.

**Table 10: SCA-X/CHV-X 50 - 65 (2 - 2½ in.)**

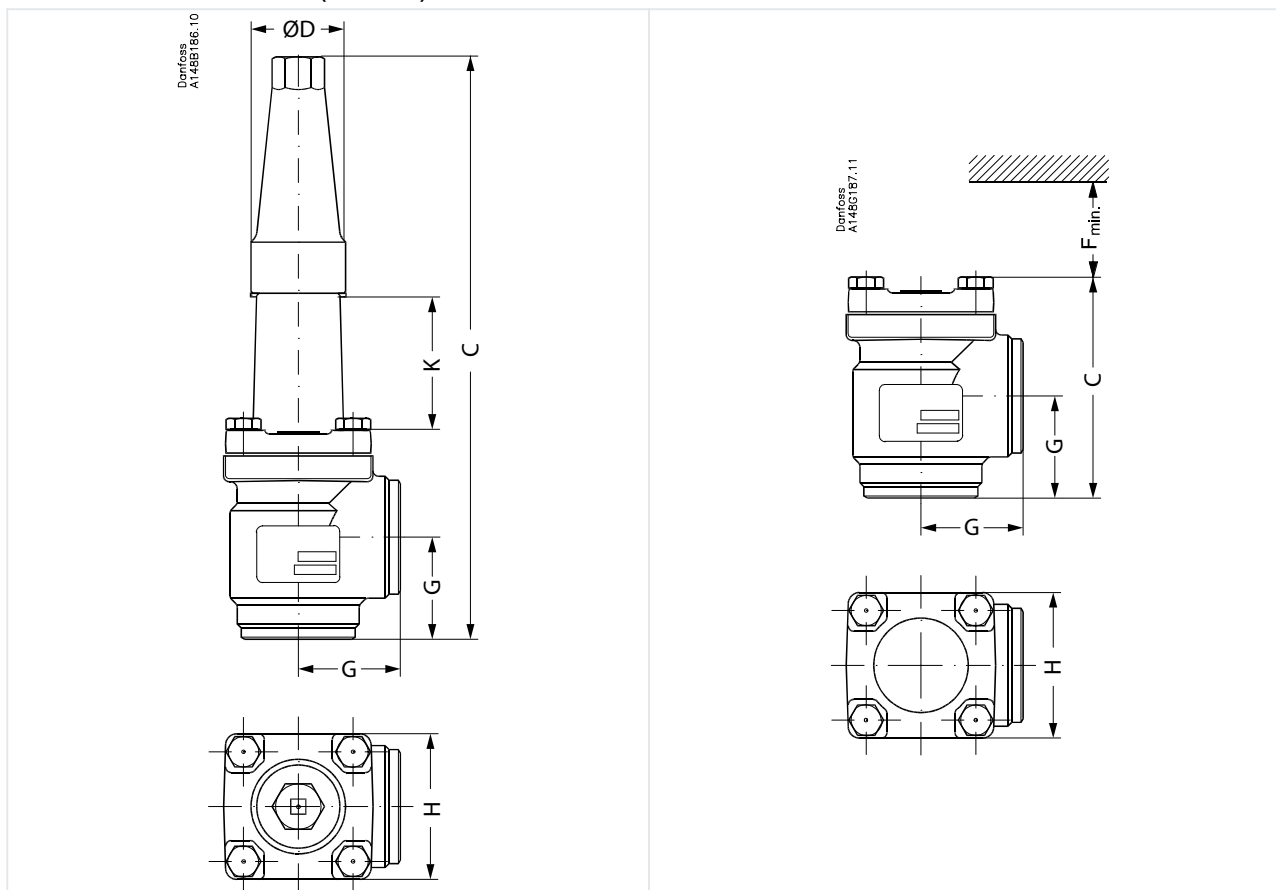

**Table 11: SCA-X**

Valve size		K	C	G	ØD	H	Weight
SCA-X 50SCA-X (2)	mm	70	315	60	50	77	3.8 kg
	in.	2.76	12.4	2.36	1.97	3.03	8.40 lb
SCA-X 65SCA-X (2½)	mm	70	335	70	50	90	5.5 kg
	in.	2.76	13.19	2.76	1.97	3.54	12.16 lb

**Table 12: CHV-X**

Valve size		C	G	F <sub>min.</sub>	H	Weight
SCA-X 50	mm	132	60	92	77	3.2 kg
SCA-X (2)	in.	5.2	2.36	3.62	3.03	7.10 lb
SCA-X 65	mm	152	70	107	90	4.5 kg
SCA-X (2½)	in.	5.98	2.76	4.21	3.54	9.95 lb

Specified weights are approximate values only.

## Check and stop valve, type SCA-X and CHV-X, With butt-weld connection F

Table 13: SCA-X/CHV-X 80 - 125 (3 - 5 in.)

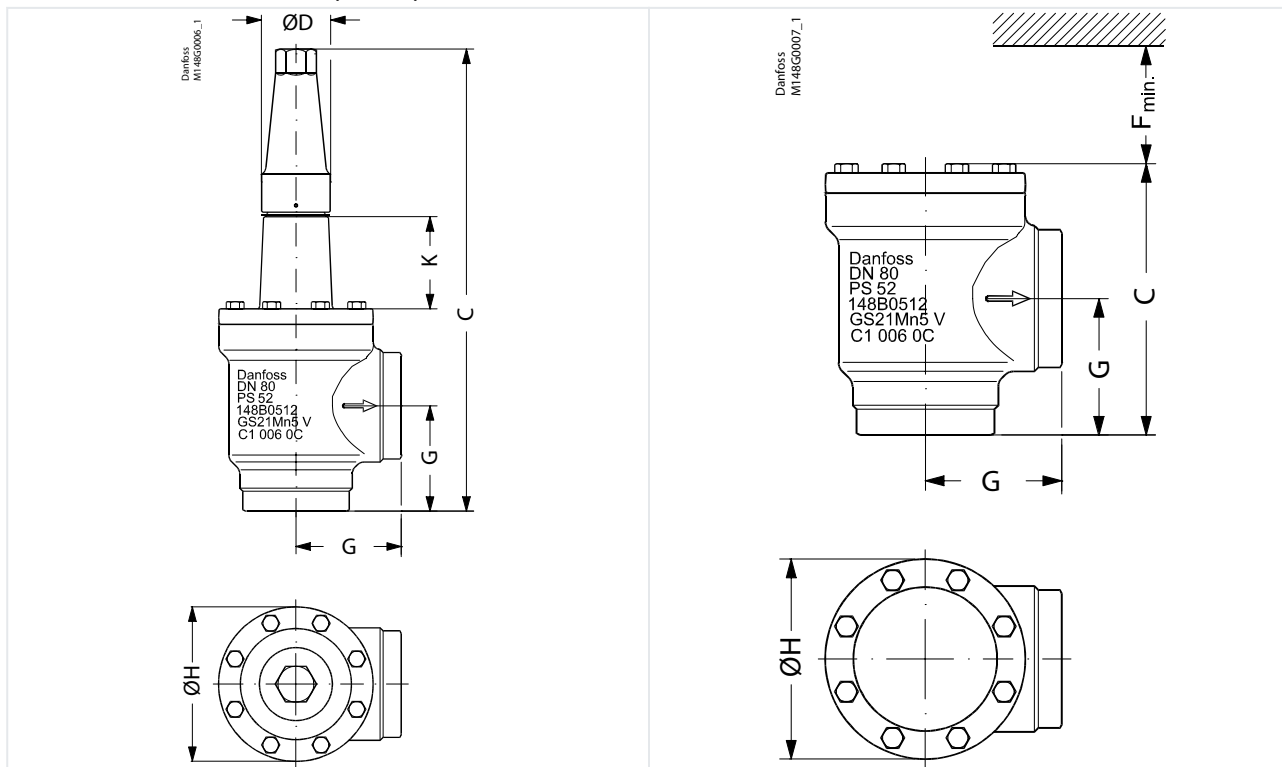

Table 14: SCA-X

Valve size	K	C	G	ØD	ØH	Weight
SCA-X 80	mm	388	90	58	129	9.7 kg
SCA-X (3)	in.	15.28	3.54	2.28	5.08	21.4 lb
SCA-X 100	mm	437	106	58	156	15.3 kg
SCA-X (4)	in.	17.2	4.17	2.28	6.14	33.7 lb
SCA-X 125	mm	533	128	74	193	28.1 kg
SCA-X (5)	in.	20.98	5.04	2.91	7.6	61.9 lb

Table 15: CHV-X

Valve size	C	G	F <sub>min.</sub>	ØH	Weight
CHV-X 80	mm	90	133	129	8.7 kg
CHV-X (3)	in.	7.44	5.24	5.08	19.23 lb
CHV-X 100	mm	223	163	156	14.3 kg
CHV-X (4)	in.	8.78	6.43	6.14	31.60 lb
CHV-X 125	mm	268	190	193	25.6 kg
CHV-X (5)	in.	10.55	7.48	7.6	56.58 lb

Specified weights are approximate values only.

## Ordering

### Ordering SVA-X from the parts programme

**Example** (select from table 1 and 2)

Figure 8: SVA-X

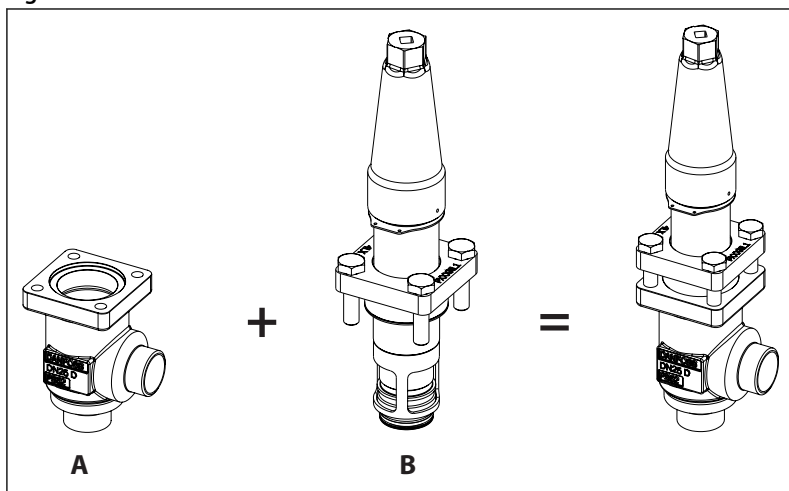

- A** Valve housing, size 25 (1 in.), butt weld F, angleway, **148B6416** [Table 21: SVL valve housings w/different connections](#)
- B** Top part, SCA-X size 25 (1 in.) **148B5482** [Table 23: SCA-X](#)

Table 16: SVL valve housings w/different connections

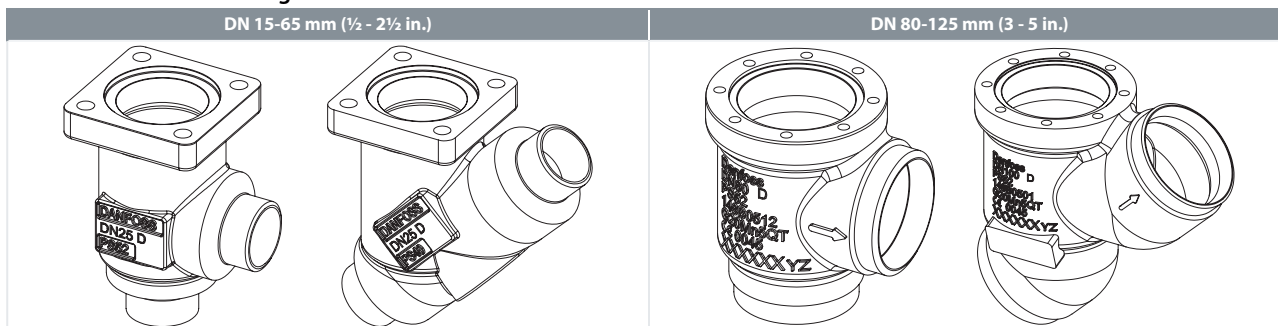

Table 17: SVL valve housings w/different connections

Sizes [DN]		DN 15-65 mm (1/2 - 2 1/2 in.)	DN 80-125 mm (3 - 5 in.)
		Valve Housing SVL	
		Butt weld F	
mm	in.	ANG	STR
15	1/2	148B6414	148B6424
20	3/4	148B6415	148B6425
25	1	148B6416	148B6426
32	1 1/4	148B6417	148B6427
40	1 1/2	148B6418	148B6428
50	2	148B6419	148B6429
65	2 1/2	148B6420	148B6430
80	3	148B6421	148B6431
100	4	148B6422	148B6432
125	5	148B6423	148B6433

Check and stop valve, type SCA-X and CHV-X, With butt-weld connection F

Table 18: SCA-X complete top part including gaskets and bolts

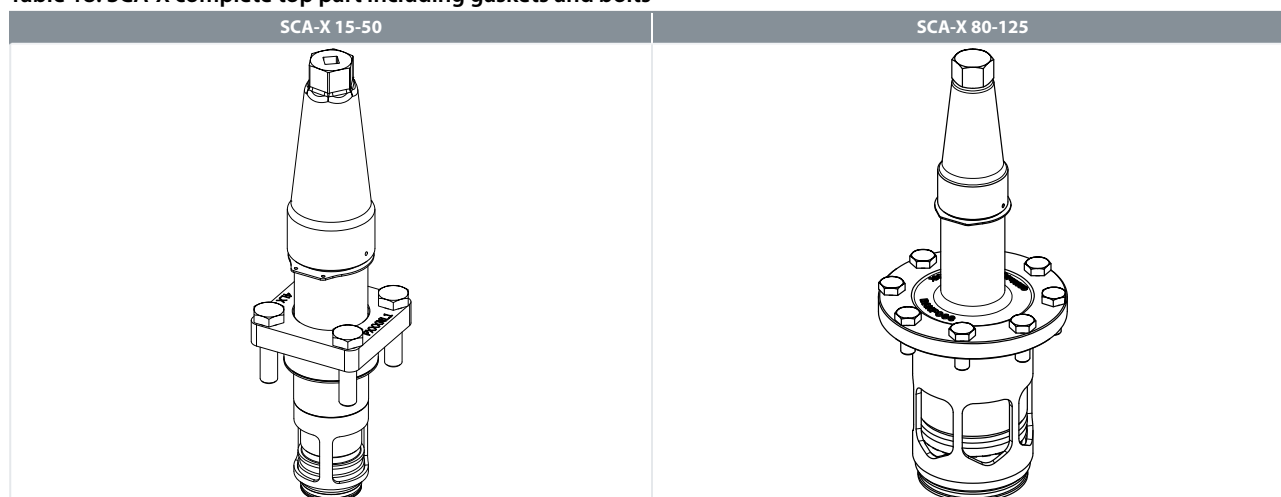
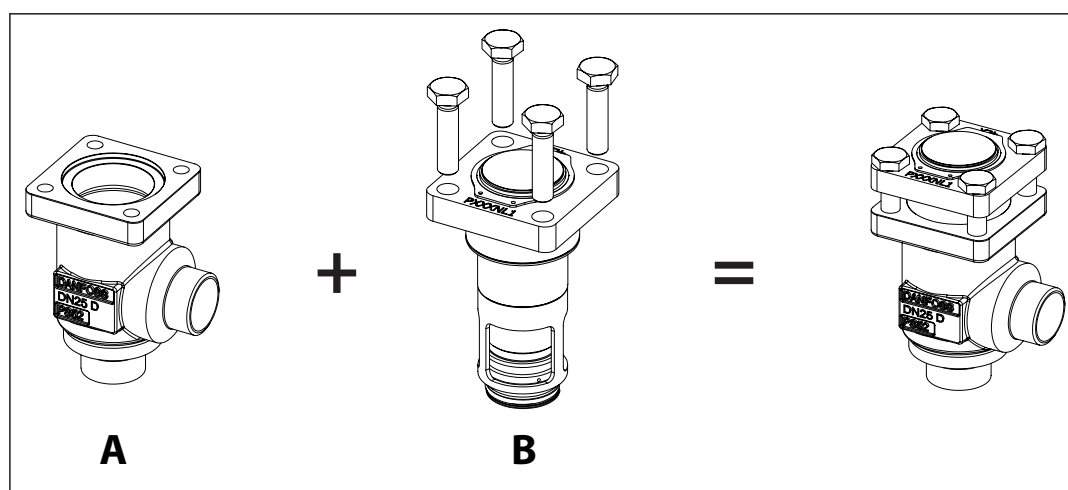

Table 19: SCA-X

Sizes [DN]		SCA-X 15-50	SCA-X 80-125
		Complete top part	
mm	in.	SCA-X	
15	½	148B5282	
20	¾		
25	1		
32	1¼	148B5482	
40	1½		
50	2	148B5735	
65	2½	148B5825	
80	3	148B5918	
100	4	148B6019	
125	5	148B6118	

**Ordering CHV-X from the parts programme**

**Example** (select from table 1 and 2)



- A** Valve housing, size 25 (1 in.), butt weld F, angleway, **148B6416** [Table 21: SVL valve housings w/different connections](#)
- B** Top part, CHV-X size 25 (1 in.) **148B5483** [Table 23: SCA-X](#)

Check and stop valve, type SCA-X and CHV-X, With butt-weld connection F

Table 20: CHV-X valve housings w/different connections

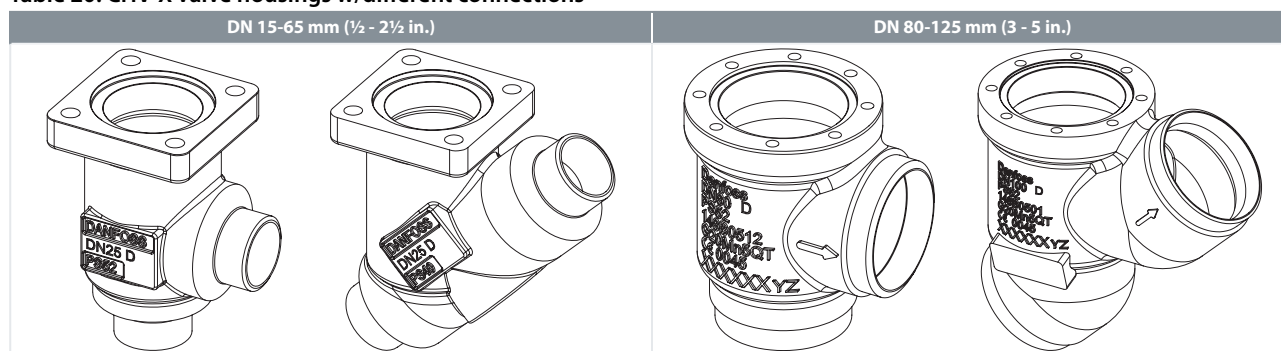

Table 21: CHV-X valve housings w/different connections

Sizes [DN]		DN 15-65 mm (1/2 - 2 1/2 in.)	DN 80-125 mm (3 - 5 in.)
		Valve Housing SVL	
		Butt weld F	
mm	in.	ANG	STR
15	1/2	148B6414	148B6424
20	3/4	148B6415	148B6425
25	1	148B6416	148B6426
32	1 1/4	148B6417	148B6427
40	1 1/2	148B6418	148B6428
50	2	148B6419	148B6429
65	2 1/2	148B6420	148B6430
80	3	148B6421	148B6431
100	4	148B6422	148B6432
125	5	148B6423	148B6433

Table 22: CHV-X complete top part including gaskets and bolts

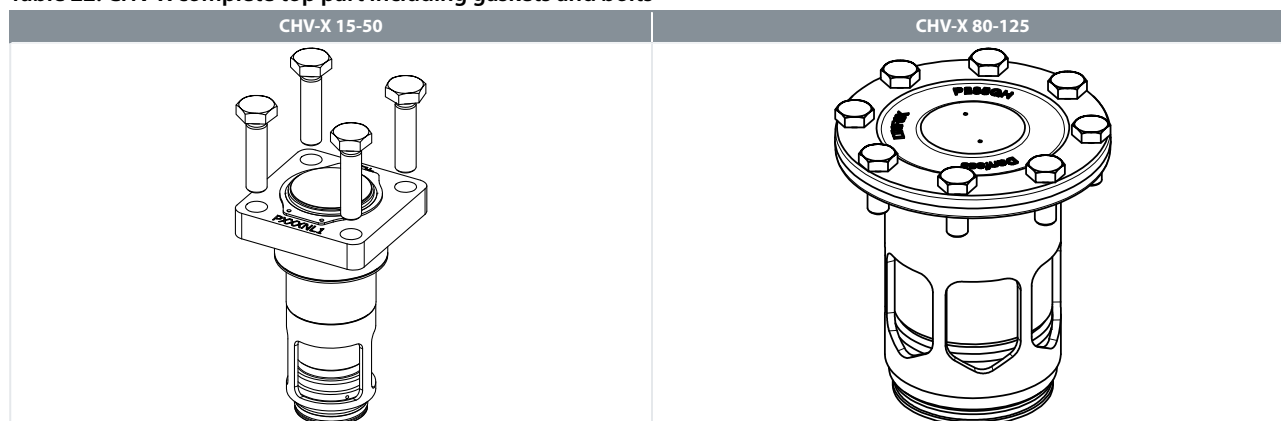

Table 23: CHV-X

Sizes [DN]		SCA-X 15-50	SCA-X 80-125
		Complete top part	
mm	in.	SCA-X	
15	1/2	148B5283	
20	3/4	148B5483	
25	1	148B5747	
32	1 1/4	148B5827	
40	1 1/2	148B5919	
50	2	148B6022	
65	2 1/2	148B6119	
80	3		
100	4		
125	5		



**Certificates, declarations and approvals**

The list contains all certificates, declarations, and approvals for this product type. Individual code number may have some or all of these approvals, and certain local approvals may not appear on the list.

Some approvals may change over time. You can check the most current status at danfoss.com or contact your local Danfoss representative if you have any questions.

**Pressure Equipment Directive (PED)**

REG valves are approved according to the European standard specified in the Pressure Equipment Directive and are CE marked.

**Table 24: Pressure Equipment Directive (PED)**

REG-SA and REG-SB valves		
Nominal bore	DN = < 25 mm (1 in.)	DN32 - 65 mm (1¼ - 2½ in.)
Classified for	Fluid group I	
Category	Article 3, paragraph 3	II

## Online support

Danfoss offers a wide range of support along with our products, including digital product information, software, mobile apps, and expert guidance. See the possibilities below.

### The Danfoss Product Store



The Danfoss Product Store is your one-stop shop for everything product related—no matter where you are in the world or what area of the cooling industry you work in. Get quick access to essential information like product specs, code numbers, technical documentation, certifications, accessories, and more.

Start browsing at [store.danfoss.com](https://store.danfoss.com).

### Find technical documentation



Find the technical documentation you need to get your project up and running. Get direct access to our official collection of data sheets, certificates and declarations, manuals and guides, 3D models and drawings, case stories, brochures, and much more.

Start searching now at [www.danfoss.com/en/service-and-support/documentation](https://www.danfoss.com/en/service-and-support/documentation).

### Danfoss Learning



Danfoss Learning is a free online learning platform. It features courses and materials specifically designed to help engineers, installers, service technicians, and wholesalers better understand the products, applications, industry topics, and trends that will help you do your job better.

Create your Danfoss Learning account for free at [www.danfoss.com/en/service-and-support/learning](https://www.danfoss.com/en/service-and-support/learning).

### Get local information and support



Local Danfoss websites are the main sources for help and information about our company and products. Find product availability, get the latest regional news, or connect with a nearby expert—all in your own language.

Find your local Danfoss website here: [www.danfoss.com/en/choose-region](https://www.danfoss.com/en/choose-region).

### Spare Parts



Get access to the Danfoss spare parts and service kit catalog right from your smartphone. The app contains a wide range of components for air conditioning and refrigeration applications, such as valves, strainers, pressure switches, and sensors.

Download the Spare Parts app for free at [www.danfoss.com/en/service-and-support/downloads](https://www.danfoss.com/en/service-and-support/downloads).

### Coolselector®2 - find the best components for you HVAC/R system



Coolselector®2 makes it easy for engineers, consultants, and designers to find and order the best components for refrigeration and air conditioning systems. Run calculations based on your operating conditions and then choose the best setup for your system design.

Download Coolselector®2 for free at [coolselector.danfoss.com](https://coolselector.danfoss.com).

### Danfoss A/S

Climate Solutions • [danfoss.com](https://danfoss.com) • +45 7488 2222

Any information, including, but not limited to information on selection of product, its application or use, product design, weight, dimensions, capacity or any other technical data in product manuals, catalogues descriptions, advertisements, etc. and whether made available in writing, orally, electronically, online or via download, shall be considered informative, and is only binding if and to the extent, explicit reference is made in a quotation or order confirmation. Danfoss cannot accept any responsibility for possible errors in catalogues, brochures, videos and other material. Danfoss reserves the right to alter its products without notice. This also applies to products ordered but not delivered provided that such alterations can be made without changes to form, fit or function of the product.

All trademarks in this material are property of Danfoss A/S or Danfoss group companies. Danfoss and the Danfoss logo are trademarks of Danfoss A/S. All rights reserved.